

404612-2

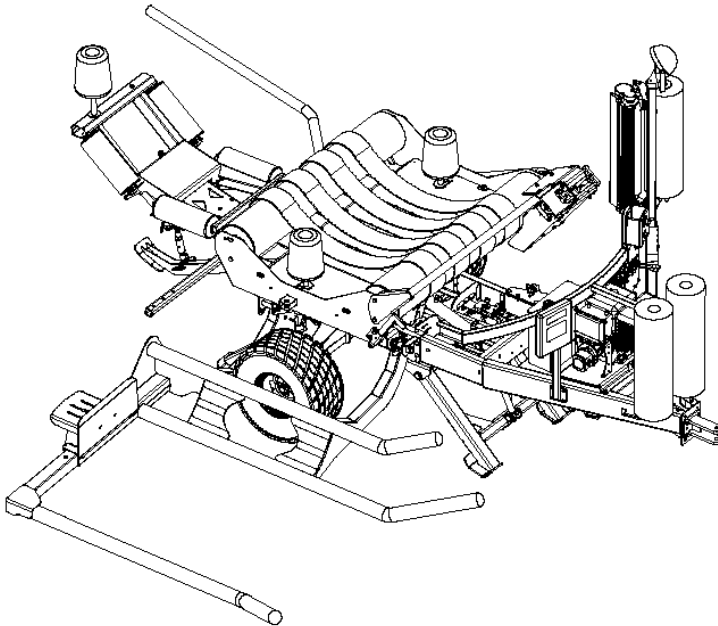

**Round Bale Wrapper
RB 680**



**Operator's Manual
2011**

For safe and proper functioning please:

- 1.** Read the manual.
- 2.** Follow the safety instructions.
- 3.** Follow the start-up steps given on the last page of your manual.
- 4.** In case of sale or transfer, give this manual to the new owner.

The illustrations in this manual are presented for your reference according to the latest information available at the moment of printing. ANDERSON GROUP reserves the right to modify its machines without advance notice.

Table of Contents

1 ANDERSON Limited Warranty	8
One-Year Limited Warranty	8
Documents	8
Problem Resolution	8
Modifications	8
Warranty Exemptions	10
Exclusive Remedy	10
2 Safety	11
Safe Operators.....	11
Danger Zone.....	11
Secure Attachment to the Tractor	11
Dangerous Situations	11
Prevention	11
Safe Maintenance and Repair.....	11
Fuel	11
Hydraulic Oil.....	12
Travelling Safely on Public Roads.....	12
End of Operation.....	13
3 General Characteristics and Specifications	14
General Specifications	15
4 Adjustment Procedures.....	16
Verifications Before Each Use.....	16
Installing the Plastic Film Roll	16
Testing the Plastic Film Stretcher	17
Adjusting the Two Support Rollers	17
Adjusting the Plastic Film Cutter.....	18
5 Operating Procedures.....	19
5.1 Moving the Bale Wrapper	19
Short and Medium Distances.....	19
Safety Measures	19
5.2 Using the Computer.....	19
Particularities of the 680 Bale Wrapper.....	19
General Characteristics of the Computer.....	19
First Start-Up of a New Machine.....	20
Setting Up a Remote Control	20
Aligning Your Bale Wrapper	22
Overview of MENUS Mode of the TAC-08 Computer	22
MENUS Mode Error Messages	24
Unloading Jam	26
Adjustments Mode of the TAC-08 Computer	27
5.3 Start and End Wrapping.....	28
Start	28
First Bale.....	28
End Bale Wrapping.....	28
Levers (Figure 5.5).....	29
5.4 Wrapping Without Remote Control	29
Start	29
Error Messages	29
6 Maintenance Procedures	30
Maintenance	30
Grease Gun Lubrication	30

Other Lubrication Points	34
Cleaning and Other Maintenance	35
Storage	35
7 Troubleshooting: Problems and Solutions.....	36
Reset Procedure	38
8 Optional Equipment.....	40
Stabilizers	40
Modifying Gears to Reduce Stretch Ratio	40
Bale Loading Arm and Film Roll Support	40
Installing the Bale Loading Arm Control	41
Double Roll Plastic Unit.....	48
Start-Up Procedures	49

List of Illustrations

Figure 2.1 Attaching the turntable.....	12
Figure 2.2 Closing the fuel valve.	13
Figure 3.1 Components of the wrapper.....	14
Figure 3.2 Exterior dimensions for the base model	15
Figure 3.3 Exterior dimensions for model with optional.....	15
Figure 4.1 Installing the film roll.....	16
Figure 4.2 Direction of film unwinding	17
Figure 4.3 Adjusting the support rollers	17
Figure 4.4 Plastic film cutter blade.....	18
Figure 5.1 TAC-08 remote control (right) and TAC-08C receiver (left).....	19
Figure 5.2 Interior of TAC-08C receiver	21
Figure 5.3 Turntable gear	25
Figure 5.4 Unloading sensor error	26
Figure 5.5 Levers	28
Figure 6.1 Grease gun lubrication.....	30
Figure 6.2 Other lubrication 1	34
Figure 6.3 Other lubrication 2 (through the hole in the guard)	34
Figure 7.1 Fuse cables.....	38
Figure 7.2 Starter fuse.....	39
Figure 7.3 Electrical connections	39
Figure 8.1 Stabilizers	40
Figure 8.2 Bale Loading Arm	41
Figure 8.3 Battery connection	41
Figure 8.4 Controller connection.....	42
Figure 8.5 Valve connection	42
Figure 8.6 Controller support	42
Figure 8.7 Bale unloading platform D	43
Figure 8.8 Bale unloading platform D3.....	43
Figure 8.9 Accumulator of the unloading arm.....	47
Figure 8.10 Double stretch roll.....	48

How to Reach Us

When you contact us, always provide us with the following information:

- Your name, address, and telephone number;
- Product model and serial number;
- Purchase date and invoice number;
- Dealer name, address, and telephone number and salesperson name;
- Precise and detailed description of your problem.

Address: **ANDERSON GROUP**
5125 de la Plaisance
Chester ville (Québec)
CANADA G0P 1J0

Email Service: service@grpanderson.com

Fax Service: 1-819-382-2218

Website: www.grpanderson.com

ANDERSON LIMITED WARRANTY FORM

Warranty form must be completed and returned.

Please fill in this form with information about your new machine. **Please return this form to us in the 15 days following the date of delivery** to validate your warranty. Details of the warranty provided can be found in the operator's manual.

Warranty Validation

(to be mailed or faxed within 15 days)

Type of Machine:	
Model:	
Options:	
Serial Number:	
Date of Sale to Customer:	
Customer Name:	
Customer Address:	
Customer Telephone Number:	
Dealer Name:	
Salesperson Name:	
Dealer Address:	
Salesperson signature:	
Customer signature:	

FAX: 1-819-382-2218

For your personal records, we recommend that you fill in this form with information about your machine.

Type of Machine:	
Model:	
Options:	
Serial Number:	
Date of Sale to Customer:	
Customer Name:	
Customer Address:	
Customer Telephone Number:	
Dealer Name:	
Salesperson Name:	
Dealer Address:	
Salesperson Signature:	
Customer Signature:	

1 ANDERSON Limited Warranty

One-Year Limited Warranty

In the year following the purchase of a new machine, if your ANDERSON equipment fails to operate properly due to defective materials, manufacturing, or assembly, our company will furnish replacement parts and repair your machine free of charge.

Documents

Keep your original invoice or a photocopy. Please refer to your invoice or to the information on the preceding page whenever you order parts, for any questions about the operating procedures of your machine or for any questions you might have concerning your warranty.

Problem Resolution

Your satisfaction is a priority for your dealer and for us. Normally, all problems concerning our products are taken care of by the dealer's service department. Please follow the following steps if you are not satisfied after consulting your dealer:

- First, let it be understood that our warranty is void if your equipment has been modified without our express authorization. Let it also be understood that we alone will determine the cause of the problem or how the machine was broken. Please note that all repairs must be authorized before any work is performed to ensure that your machine remains covered by the warranty.
- If your problem has already been dealt with by your dealer's service department but you are not completely satisfied, please contact one of the managers of the dealership that sold you the Anderson machine. In most cases, your problem can be solved at this level.
- If your problem still has not been resolved to your satisfaction after this step, please contact us directly.

When you contact us, always provide us with the following information:

- Your name, address, and telephone number;
 - Product model and serial number;
 - Purchase date and invoice number;
 - Dealer name, address, and telephone number and salesperson name;
 - Precise and detailed description of your problem.
- 1.3.4 After reviewing all aspects of the problem, we will rapidly communicate our decision to you and, if applicable, the steps taken to resolve the situation. It is nonetheless likely that your problem will be solved by your dealer using his team and specialized equipment. We therefore strongly suggest that if you need any kind of help, your first contact should be made directly with your dealer.

Modifications

Given that our desire is to always improve our products, our company reserves the right to modify its machines, their characteristics, and their parts at any time without advance notice or obligation.

Thank you for placing your confidence in us

Dany Poisson, President
Anderson Group



**ANDERSON GROUP
LIMITED WARRANTY**

The **one-year warranty** period will begin on the date the new equipment is sold to the customer. However, if your equipment is used for **commercial or rental purposes**, this warranty will only be valid for a period of **90 days or a maximum of 3500 bales for in-line bale wrappers and 2500 bales for individual bale wrappers beginning on the date of purchase.**

1. During the year following the purchase of a new machine, if your ANDERSON equipment fails to function properly due to defective design, materials, manufacturing, or assembly, our company will repair your equipment free of charge.
2. Replacement or repair of equipment parts will be performed by the dealer or by our technician. This includes parts and labour **only if preauthorized by our customer service department.**
3. However, the customer will be responsible for transporting the equipment to/from the authorized dealer's head office.
4. The dealer will describe the terms of this warranty to the customer before the retail sale and will record the date of purchase, the serial number, and the equipment description. The dealer will fax the duly completed warranty form in the 15 days following the transaction to the following number: 1-819-382-2218 to validate the warranty.
5. To have equipment repaired under the warranty, the customer must advise his dealer **as soon as possible** of the problem and request that the repairs be made according to the terms of the applicable warranty.
6. For all repair requests made to an **Anderson** dealer, you must furnish **the date of sale, the serial number, the type of equipment and options, and the owner's contact information.**
7. **Anderson Group reserves the rights to modify the warranty policy at any time without advance notice.**
8. Notwithstanding the foregoing.

Warranty Exemptions

1. **Certain parts**, such as the tires, the battery, and the Honda engine, **are covered under warranties from their respective manufacturers. Please contact the appropriate manufacturer.**
2. If the equipment has been subjected to bad treatment or negligence, has been used inappropriately, has not received necessary maintenance, has not been appropriately protected during storage, has been damaged by vandalism, bad weather, natural elements, collision, or accident.
3. Let it be understood that our warranty is void if your equipment has been modified without our express authorization.
4. This warranty **does not cover** normal maintenance services (such as adjustments, oil changes, normal wear and tear, etc.)
5. The customer will be responsible for service calls and/or transporting the equipment to/from the authorized dealer's head office. **The warranty does not cover towing expenses.**
6. If parts or accessories other than those **manufactured or sold by Anderson Group** have been used without the authorization of the customer service department, and if we decide that their use negatively impacts the performance, stability, or reliability of the equipment.

Exclusive Remedy

To the extent permitted by law, the purchaser's exclusive remedy in connection with the breach or performance of any warranty on the equipment are those set forth in this warranty.

In no event will Anderson Group be liable for any incidental or consequential damages or injuries, including but not limited to loss of profits, rental of substitute equipment, or other commercial or personal loss or damages arising as a result of a fundamental breach or breach of a fundamental term.

No Dealer Warranty

Except for conditions or warranties which may not be excluded by law, the selling dealer makes no warranty of its own on any item warranted by **Anderson Group** unless it delivers to the purchaser a separate written warranty document specifically warranting the item. **The selling dealer has no authority to make any representation or promise on behalf of Anderson Group or to modify the terms or limitations of this warranty in any way.**

Right of Modification

Given that our desire is to always improve our products, our company reserves the right to modify its machines, their characteristics, and their parts at any time **without advance notice or obligation.**

ANDERSON GROUP

5125 de la Plaisance

Chesterville (Québec)

CANADA GOP 1J0

Email Service: service@grpanderson.com

Fax Service: (819) 382-2218

2 Safety

Your ANDERSON bale wrapper was designed to reduce to a minimum the risks to the operator. However, it must be used only for the work it was designed for. Additionally, since it includes a powerful hydraulic system, moving metal parts, and a gasoline engine and all these elements can cause serious injury to humans or animals, it is strongly recommended to read and to closely adhere to the following guidelines.

Safe Operators

Be familiar with operating procedures before using your ANDERSON bale wrapper. Also insist that these directions be followed by all who use your bale wrapper. Make sure that your operators know the emergency telephone numbers and the location of your first aid kit. Only allow the bale wrapper to be used by responsible people who have been fully trained in its safe operation.

Danger Zone

Do not allow yourself to be disturbed during the installation or the operation of the machine. As an operator, you must be the only person to move about the machine within a security zone of 5 metres (16 feet) diameter. Keep all other people, especially children, away from the site, as well as domestic animals.

Secure Attachment to the Tractor

The machine must be properly attached to the fixed drawbar of the tractor so that the bale wrapper is positioned as high as possible. To increase the stability of the bale wrapper, choose a flat and level ground and use the stabilizers, if you have that option.

Dangerous Situations

Pay attention to the stickers and the warning labels that appear on your machine. Know how to make an emergency stop. Before starting the engine, make sure that all controls are in neutral position. It is always dangerous to stand on the machine. Keep fingers, hands, and feet away from moving parts: chains, gears, etc.

Prevention

The clothes that you wear as an operator must be safe. Avoid wide sleeves and pants, scarves, and shirt or coat sleeves that could become stuck in the moving parts of the machine. Additionally, wear adequate hearing protection to reduce the danger of hearing loss due to continued exposure to the noise of the bale wrapper. Also use an approved mask in dusty conditions. If you work in the evening or at night, make sure that you have sufficient lighting to work safely. Have a working fire extinguisher within arm's reach. Keep the protective shields and other security devices in place and never use your bale wrapper if they have been removed or damaged.

Safe Maintenance and Repair

Stop the engine and remove the switch key (from the tractor and/or from the hydraulic unit) before performing maintenance, adjustments, or repairs. Release the oil pressure before moving beneath certain hydraulically lifted parts and be aware of the blade of the plastic film cutter. Replace all defective or worn out parts. We recommend you use original or approved parts in order to protect your warranty and to obtain optimal performance from your machine.

Fuel

Gasoline is a very flammable substance which must be handled with care in an approved container when you fill the engine tank of your hydraulic unit. Put back in place and firmly

tighten the tank cap and wipe away any spilled fuel. Never add gasoline when the engine is hot or operating. Have a working fire extinguisher within arm's reach near the baling site.

Hydraulic Oil

Any leak of pressurized oil can cause serious injuries. Do not use your hands to locate a leak, but rather an object such as a piece of cardboard. Stop the engine and release the pressure before disconnecting or reconnecting the lines. Firmly tighten all connections before restarting the engine or reapplying hydraulic pressure.



WARNING !

Any hydraulic fluid that makes contact on or underneath the skin must be removed within hours by a doctor familiar with this type of injury. Without intervention, very serious problems may result.

Travelling Safely on Public Roads

If you travel on public roads, you are responsible for respecting the identification and lighting regulations of your region. We recommend that you always attach a security chain to the hitch point between the machine and your tractor and that you lock the coupling link with a pin.

Also attach the turntable's (Figure 2.1) L-shaped latch (1). Rotate the table as needed so that the latch faces the notch (2) at the front of the frame. Remove the latch pin. Slide the latch toward the notch and insert the latch shaft. Place the pin in the hole of the notch.

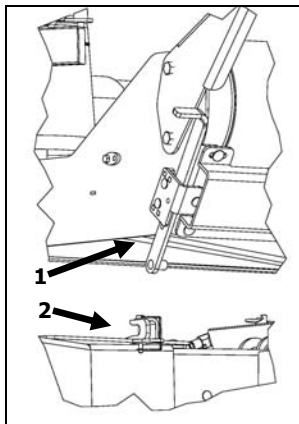

Figure 2.1 Attaching the turntable

End of Operation

If you will not use the bale wrapper again for a long period of time, do not forget to close the engine fuel valve (1), located beneath the choke on the right side of the engine (Figure 2.2).

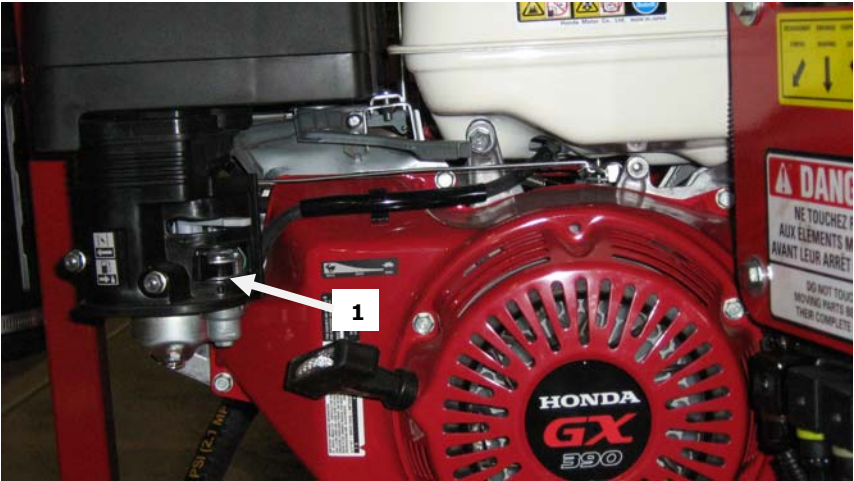

Figure 2.2 Closing the fuel valve.

3 General Characteristics and Specifications

Congratulations! You are now the owner of a n AND ERSON bale wrapper, a high-quality machine designed for the separate storage of round bales of up to 5 feet (1.5m) in diameter. This agricultural machine is carefully manufactured by our company to give you many years of reliable performance.

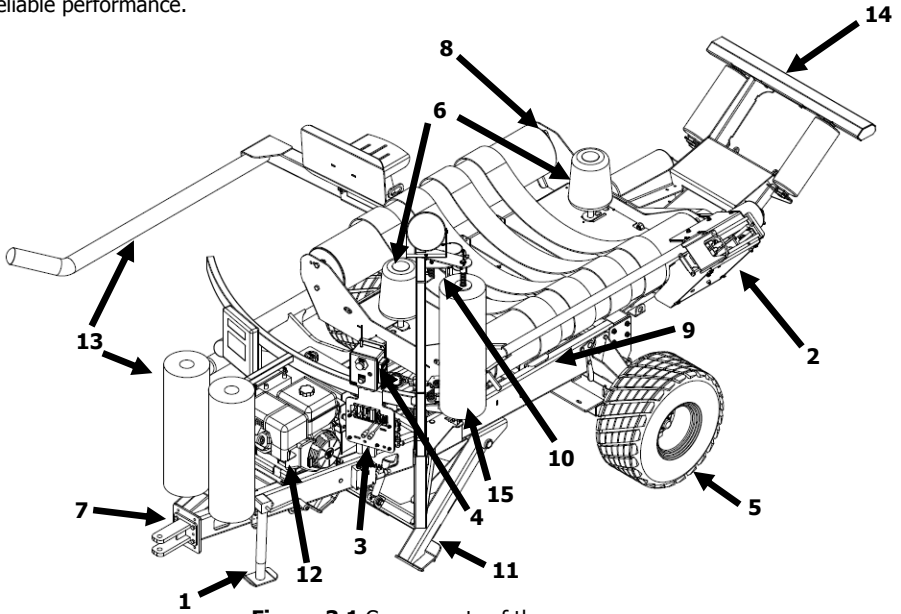

Figure 3.1 Components of the wrapper

Components	#
Jack with side crank	1
Film cutter	2
Manual controls	3
Computer	4
26 x 12 x 12 Tires (8 plies)	5
Roller support	6
Tongue	7
Turntable	8
Tilting table	9
Plastic film stretcher	10
Optional Components	#
Stabilizers	11
Hydraulic unit with 13HP Honda motor and electric starter, alternator, and work lights	12
Loading arm and plastic film roll support	13
Unloading platform (D) (regular)	14
Unloading platform (D3) (3 positions)	---
Double film roll unit	15

* It is not possible to combine the loading arm and stabilizer options

General Specifications

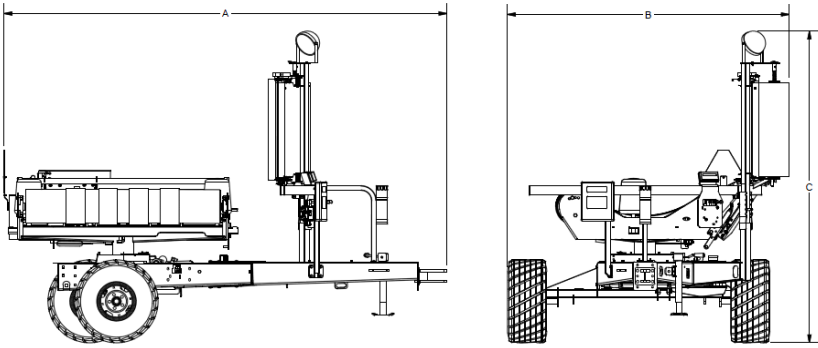

Figure 3.2 Exterior dimensions for the base model

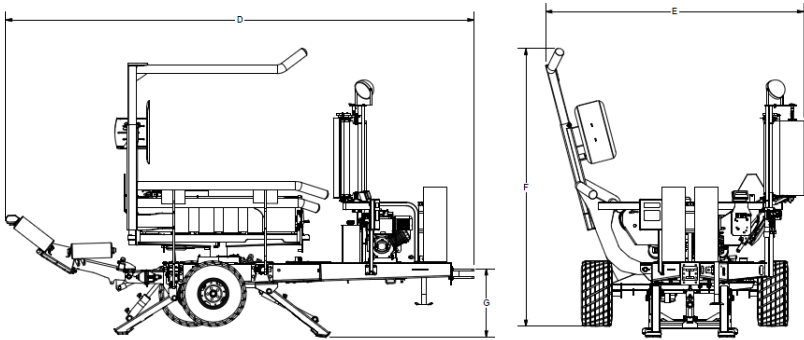

Figure 3.3 Exterior dimensions for model with optional

Dimensions and Weight for base model		Dimensions and Weight for model with optional	
Length (A)	140 po (3,55m)	Length (D)	187,50 po (4,77m)
Width (B)	89 po (2,26m)	Width (E)	100,75 po (2,56m)
Height (C)	99 po (2,51m)	Height (F)	118,50 po (3,01m)
Total weight*	1896 lbs (860 kg)	Weight of stabilizers	250 lbs (113 kg)
* Without hydraulic unit or optional components.		Weight of hydraulic unit	386 lbs (175 kg)
		Weight of loading arm	Arm: 465 lbs (210 kg) Weight: 550 lbs (249 kg)
		Poids support de rouleaux plastiques	20 lbs (9 kg)
		Weight of unloading platform D	420 lbs (190 kg)
		Weight of unloading platform D3	550 lbs (250 kg)
		Weight of double film roll unit	55 lbs (25 kg)

4 Adjustment Procedures

Verifications Before Each Use

Check the level hydraulic oil in the tank of your unit. Check the oil level in the Honda engine, if applicable, as well as the need for fuel. Open the fuel valve and check the engine air filter. If necessary, lubricate the machine well after each day of use. Every day, check the cleanliness of the plastic film stretcher rollers. Clean them as necessary with penetrating oil, rubbing alcohol, or paint thinner.

At start-up, your bale wrapper must be placed in the most horizontal position possible. Detach the turntable's L-shaped latch (Figure 2.1). If you have the stabilizer option, start the machine and pull the 2 levers of the control to put them in place (Figure 5.5). If the film roll is in place, check if the edge of the plastic is properly held by the clamp of the film cutter. If not, tighten the clamp around the plastic film by pulling the lever (Figure 5.5).

Installing the Plastic Film Roll

When the film roll is empty, remove the spool by pushing it upward to compress the retaining spring of the upper support (Figure 4.1). Install the new roll in the same manner.

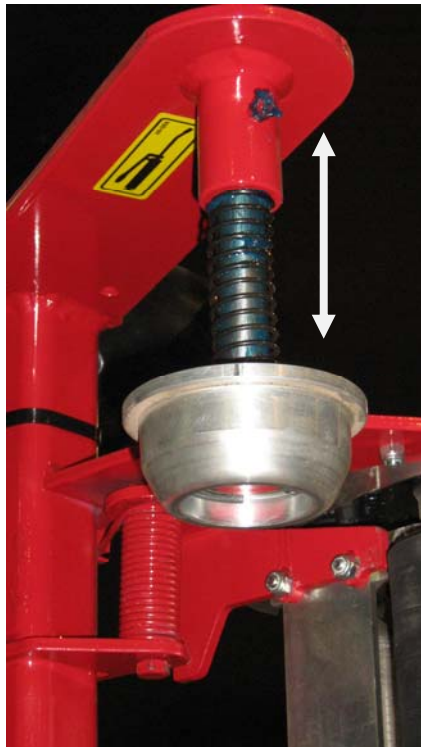

Figure 4.1 Installing the film roll

Follow the diagram (Figure 4.2) to unroll the start of the film between the rubber roller and an aluminium roller, then around the other aluminium roller. Open the film cutter with the lever and place it at the edge of the film. Close the clamp of the film cutter to hold it in place.

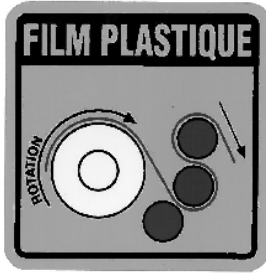

Figure 4.2 Direction of film unwinding



WARNING !

Avoid leaving the plastic film rolls in the sun for a long period of time before using them. Prolonged sun exposure can cause the film to break or deteriorate during wrapping.

Testing the Plastic Film Stretcher

To check the effectiveness of your system, draw a 10-inch (25 cm) horizontal line on your plastic film roll with a felt-tip pen. Turn the table about one revolution and stop. Once the line has passed the aluminium rollers, measure it on the bale. If it has stretched up to a length of approximately 16.5 inches (41 cm), this means that your film stretcher is working properly. If the film does not stretch properly, check the gears of the film stretcher, and if the plastic film roll and the free roller turn freely, clean the aluminium rollers.

Adjusting the Two Support Rollers

These two conically shaped support rollers are made of rigid plastic and are placed on each end of the table between the feed rollers to hold your bale in place. In the factory, they are placed 48 inches (1.2 m) apart to hold bales of 48 inches (1.2 m) in width. Move them together or apart as necessary according to the average width of your bales by removing the pins beneath the table and changing their position. The support rollers can hold bales up to 60 inches (1.5 m) in width (Figure 4.3).

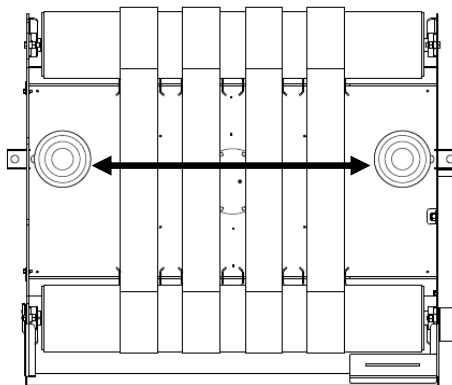

Figure 4.3 Adjusting the support rollers

Adjusting the Plastic Film Cutter

First check the condition of the stainless steel blade (1) in the diagram of (Figure 4.4) and change it as necessary.

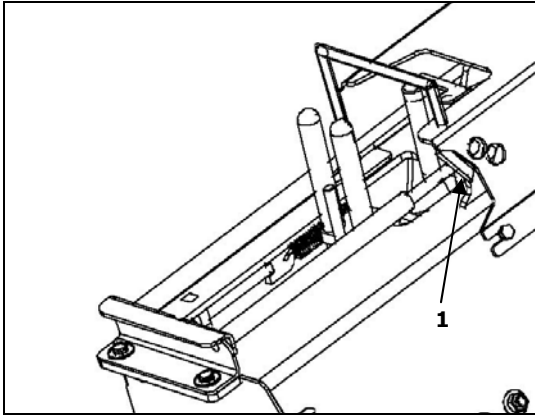

Figure 4.4 Plastic film cutter blade

Additionally, by pushing the plastic in the direction of the blade, the fingers normally push the rubber stopper to the adjustment bolt in the back. Conversely, a spring provides tension from the stopper toward the fingers in order to hold onto the end of the plastic for the next bale. This bolt and this spring can be adjusted as necessary.

5 Operating Procedures

5.1 Moving the Bale Wrapper

Short and Medium Distances

Your machine can be moved short and medium distances behind a tractor. Fasten the turntable latch (Figure 2.1). Attach the machine and attach a security chain to the ring provided for this purpose on the draw bar. On public roads, follow the traffic regulations of your region for agricultural machines, including those concerning the use of agricultural machines by minors.

Safety Measures



WARNING !

Regardless of method, during transportation, do not stand on and do not let anyone else stand on the machine.



WARNING !

Close the fuel valve if it is necessary, because the gasoline could leak into the engine base.

5.2 Using the Computer

Particularities of the Bale Wrapper

The 680 bale wrapper has a computer with an electronic remote control. Additionally, the hydraulic unit and the stabilizer option allow a single operator to perform all operations: loading the bale by tractor and remotely starting the wrapping process, which ends with cutting the plastic film and automatically unloading the wrapped bale. The tractor operator can then load a new bale and leave to put the first bale in storage while the new bale is wrapped in turn.

General Characteristics of the Computer

The computer includes two components: the TAC-08C receiver and the TAC-08 remote control (Figure 5.1). The grey case of the receiver is installed on the bale wrapper. The receiver requires a minimum of 12 V at all times and contains 3 fuses (2A, 20A, and 25A).



Figure 5.1 TAC-08 remote control (right) and TAC-08C receiver (left)

To start up the TAC-08 receiver, pull the red POWER knob. This can also serve as an emergency stop if you push on it. The blue "WRAPPING" button underneath will start blinking to indicate that the machine is ready to be aligned.

To start up your TAC-08 remote control, push the black button on the bottom left. Five windows will light up: a central 2-line window for messages and 4 secondary windows, each with a button numbered from 1 to 4. An emergency stop button is located on the bottom right. The remote control automatically turns off after 5 minutes if not used. It works with a rechargeable battery, which can be recharged with the provided AC/DC charger. You also have a wire that allows you to power the remote control using DC power from your cigarette lighter.

First Start-Up of a New Machine

Push the black button on the bottom left of your TAC-08 remote control. If your machine is new, 3 message situations are possible:

First situation: On the 2nd central line, your remote control shows the message *[searching / wrapper]* followed by *[wrapper not powered, out of range, or not associated / out of range]*. This means that your remote control cannot find the receiver. There are 3 possible reasons for this.

1. First check if the receiver's POWER knob is in working position (pulled) and if the blue button is blinking. If it is pushed in, pull it and go the second situation below.
2. If the button is pulled, check if you have a problem with the distance or the range of the remote control. If this is the case, by moving closer, you should be able to move on to the second situation.
3. If these 2 reasons do not apply, press on button 2 *[associate]* to program your TAC-08 remote control. This will bring you to the *[Adjustment 9]* menu. Go to the section "Associating a Remote Control."

Second situation - with the tractor running: Your remote controls opens in [MENU #4] – *Alignment*. This means that your remote control is indeed associated with the receiver. Go to "Aligning Your Bale Wrapper."

Third situation – with hydraulic unit: Your remote control opens in [MENU #5] *Hydraulic Unit*. If your engine is not running, use button 4 to start it. Note that the engine key must be at ON. You can also start it directly with the key, especially when it is the first start-up using the choke. You will automatically move on to [MENU #4] – *Alignment*. Go to "Aligning Your Bale Wrapper."

Setting Up a Remote Control

You are in adjustment mode 9 *[see section Adjustments Mode]*, and you see the central instruction *[To associate the TAC-08, put the receiver on remote program]*. Open the receiver cover by turning the lock. Press the small black button "operation mode" (Figure 5.2). The red indicator **Prog tele.** lights up. Press button 4 *[associate]*. The indicator **Prog tele.** blinks and then goes out and the green indicator **Etat on** lights up. Close the receiver cover.

Your remote control is associated with the receiver and a 4-figure hexadecimal code will briefly appear. You will automatically move on to the second or third situation described above.

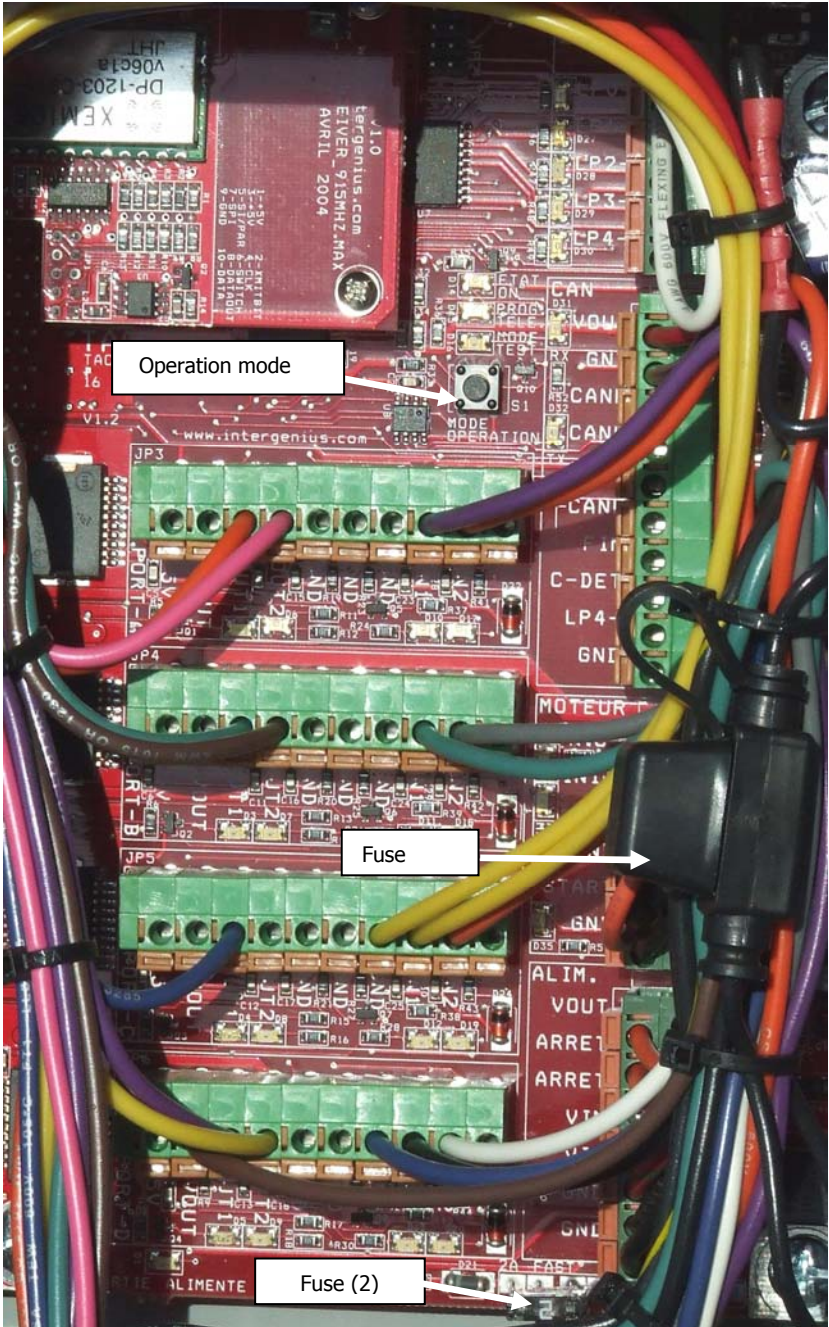

Figure 5.2 Interior of TAC-08C receiver

Aligning Your Bale Wrapper

Each time you pull the POWER button to activate your receiver and your remote control is activated, your remote control will be in [MENU #4] – *Alignment*. If you have the hydraulic unit, you will first be in [MENU #5] to start your engine, and then you will automatically move on to [MENU #4] – *Alignment*.

You will see the instruction [align wrapper] in the central window. Window 4 shows [align] and you must press button 4 to carry out this step. The turntable will autonomously perform several positioning verifications and will then place itself into proper starting position. Window 4 [align] will blink during the entire adjustment period. You will then move on automatically to MENU 1 to begin wrapping.

Note that during the day, you can stop your tractor or your hydraulic unit without pushing the POWER button on your receiver. You will not need to realign your machine. Do not forget, however, that you must perform the alignment procedure each time you use the emergency stop, either by pushing the red button on the receiver or by using the remote control.

Overview of MENUS Mode of the TAC-08 Computer

We have programmed 2 digital modes in your computer. The 1st mode contains 4 standard menus (5 menus if you have the hydraulic unit). The 2nd mode contains 9 advanced programming adjustment menus, described on page 27. Adjustments Mode of the TAC-08 Computer

NOTE: Symbols at the end of the first line of the central window:

- △: Remote control signal power indicator.
- : Battery charge level indicator.

Wrapping MENU # 1:

1 2		Button #1 to access the following menu
MENU 1		Button #2
Rev: 00 / 18	△ □	Shows the number of revolutions performed / the number of revolutions desired
Bal / (D): 0 0 0		Shows the number of bales wrapped in the day
Wrap		Button #3 to begin wrapping once the bale is loaded
3 4		Button #4

Note for window 3: During wrapping, window 3 displays the message [pause]. If you push this button, you will interrupt the process and message 3 becomes [continue]. You then have 2 choices: push button 3 again to continue wrapping or go (with the button [+]) to MENU 4 and push button 2 [Cancel] to cancel the current wrapping cycle and begin a new process. The machine will automatically place itself at the start of a new wrapping cycle.

You can move on to the following menu by pressing button 1 or [+] on the remote control. The [-] button can be used to return to the previous menu.

Note: If you have a power unit, each time that you activate the receiver (pull the red button), MENU 5 will appear to start the HONDA engine. After the engine has started, MENU 1 will appear as shown above.

1 2	
MENU 1	
Rev: 00 / 18	△ □
Bal / (D): 0 0 0	
Wrap	
3 4	

Next, push button 3 to access menu 4, then push button 4 to perform alignment.

Wrapping MENU #2:

The only difference between this menu and MENUs 1 and 3 is line 2 of the central window.

1 2		Button #1 to access the following menu
MENU 2		Button #2
Rev: 00 / 18 Δ <input type="checkbox"/>		Shows the number of revolutions performed / the number of revolutions desired
Bal / (Y): 0 0 0		Shows the number of bales wrapped in the year
Wrap		Button #3
3 4		Button #4

Wrapping MENU #3:

The only difference between this menu and MENUs 1 and 2 is line 2 of the central window.

1 2		Button #1 to access the following menu
MENU 3		Button #2
Rev: 00 / 18 Δ <input type="checkbox"/>		Shows the number of revolutions performed / the number of revolutions desired.
RPM: 0 0 / 0 0		Show's the table's actual RPM / desired RPM
Wrap		Button #3
3 4		Button #4

Note: These RPM data can be useful: if the oil flow from the tractor is insufficient, the turntable cannot attain the maximum desired RPM, does not stop correctly, and must slow down. Additionally, for protection, it will automatically reduce its RPM and wrapping performance will decrease. **Solution:** increase the oil flow from the tractor or go to a djustment MENU 2 and decrease the maximum desired RPM with button 3 or button 4.

MENU #4: Wrapper ALIGNMENT

1 2		Button #1 to access the following menu
MENU 4	Cancel	Button #2 to cancel wrapping
Align Δ <input type="checkbox"/>		Each time that you pull the receiver's power button, this message will indicate that alignment is necessary
Wrapper		
Align.		Button #3 inactive
3 4		Button #4 to align the machine

MENU #5: Hydraulic UNIT

1 2		Button #1 to access the following menu
MENU 5		Button #2 inactive
Engine Δ <input type="checkbox"/>		Indicates the engine's actual RPM
RPM: 3600		
St	art	Button #3 inactive
3 4		Button #4 to remotely start/stop the engine

Note: When the engine is running, you can access MENU 5 at all times to see the engine RPM. In the window corresponding to button 4, the word "stop" will appear. Press this button to stop the HONDA engine.

MENUS Mode Error Messages

In all the MENUS, certain error messages may appear in the central window during operation. For example, if the machine refuses to start or to function, you might see:

[Out of range]

The search for the wrapper during start-up failed. The receiver is turned off or too far away or your remote control is not associated. See the first start-up situation (Page 20)

[TAC-08 / RF Error]

Technical problem with the remote control. Must be returned to dealer for replacement.

[Version / incompatible]

Different programming between receiver and remote control. Programming must be updated.

[Hydraulic problem, lack of fuel, or loading arm too high! / Hydraul. Fuel]

Three causes of the malfunction of the table, the wrapper, or the engine. Check.

[Problem with plastic film, ripped or empty! / plastic]

This message only appears if adjustment 5, "automatic stop," is activated. A sensor underneath the plastic film stretcher no longer senses movement and stops the table. Install a new roll or, if the plastic film is broken, attach the new end of the film on the bale. Next, push button 3 to erase the error message. You will now be in MENU 1. Press button 3 [wrap] again to continue your wrapping cycle. To simulate wrapping without the plastic film, deactivate the automatic stop (plastic film sensor) in MENU 5.

Note: The normal distance of the sensor is 1/8 inch (3 mm). Adjust as necessary.

The three following error messages will appear if the sensors are not functioning correctly:

[Rotation sensor error / Rotation]

This message indicates a malfunction at the encoder level. Check if the wiring is damaged, if there is a bad contact in the connector, or if the encoder is damaged.

[Zero setting sensor error / Zero setting]

This sensor senses the presence of a hole in the toothed wheel (Figure 5.3) and stops the turntable at its initial position when the machine is being aligned. Check if the sensor light turns on when facing the metal of the tooth wheel and conversely, if it turns off when facing the hole in the toothed wheel. Check the adjustment of the sensor, which should normally be 0.095 inches (2.41 mm), and the wiring (bad contacts, cut wires, defective sensors).

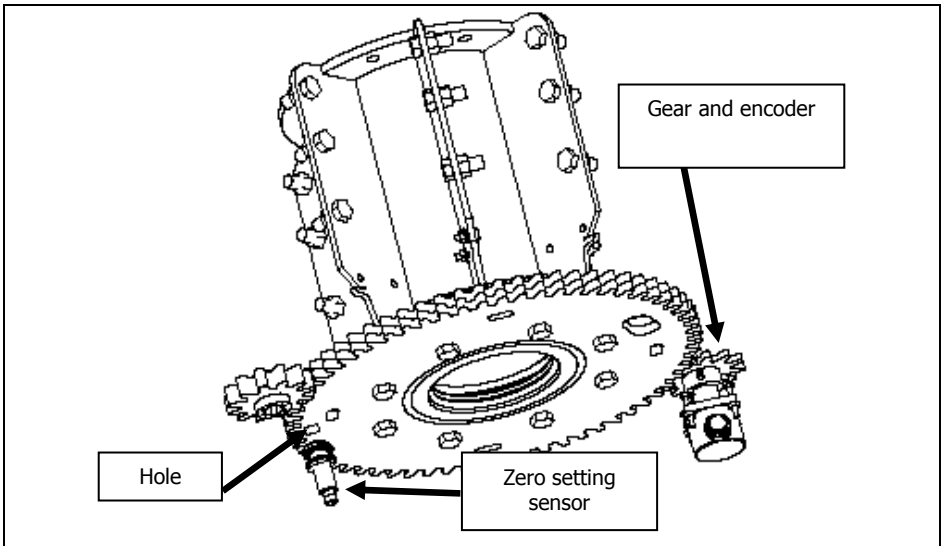

Figure 5.3 Turntable gear

[Unloading sensor error / Unloading]

This sensor is located near the right axle and limits the rise and fall of the unloading table. It senses the presence of a lower hole when the table is lowered and an upper hole when the table is raised (Figure 5.4). The sensor must be placed 1/8 inch (3 mm) from the holes. The error message indicates that the table lifts itself or is blocked and cannot lower itself into place. Exercising due caution, manually activate the table and check first if the sensor light turns on when it is not facing the hole and turns off when facing the hole. If not, verify the alignment of the sensor in lowered and raised positions. Also observe the distance of the sensor. Also consult as necessary the section on unloading jams.

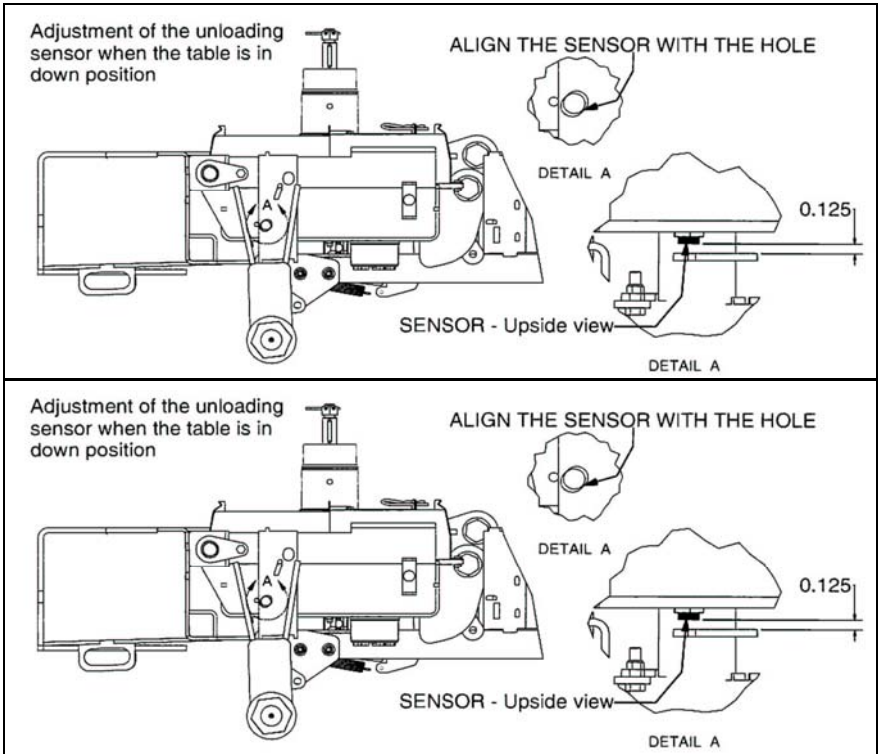

Figure 5.4 Unloading sensor error

[Other messages]

If you use the emergency stop, you will see [emergency stop].

If you install the charger, you will see [Charging battery] or [Charging finished].

Unloading Jam

Warning: If your table is not perfectly straight during unloading, a mechanical lock on prevent it from tipping. The mes sage [Unloading sensors error] will appear. Stop the machine with th e remote control and then restart it. You will be in MENU 4. Lower the table and the platform with the valve lever. Repeat the alignment procedure in MENU 4 (page 22). After alignment, closely observe t he po sition of th e table (the t table in unloadi ng po sition must be a s perpendicular as possible to the bale wrapper frame) and then go to adjustment menu 8 (Page 27). Change the position of the turntable with button 3 or button 4: [-] or [+]. You will have a choice from -5 to +5 . Next, press button 2 [Activate] and observe the re sult ob tained. Readjust as necessary.

Adjustments Mode of the TAC-08 Computer

To switch from MENUS mode to programming adjustment mode (or vice-versa), simultaneously press the buttons [+] and [-], then release.

ADJUSTMENT 1: Maximum number of revolutions to wrap a bale

Change the number as necessary with button 3 or button 4 according to the instructions given in the windows. We recommend a covering minimum of 4 layers of plastic film. Adjust your number of revolutions according to the size of the bale and forage characteristics. To move on to the next adjustment, press the [+] button on the remote control.

ADJUSTMENT 2: Maximum RPM of the turntable

If the oil flow from the tractor is insufficient, the turntable will not reach the maximum desired RPM (see MENU #3). It will also not stop properly and will have to slow down. Additionally, to protect itself, the table will automatically reduce its RPM and bale wrapping performance will diminish. **Solution:** increase oil flow from the tractor or decrease the maximum RPM desired for the table with button 3 or button 4 of the current adjustment.

ADJUSTMENT 3: Number of bales wrapped in the day

If desired, reset to zero each new day with button 3.

ADJUSTMENT 4: Choice of machine model: 680, 780SB¼, or 780SB

If your machine is a 680, choose the 680 model. If your 680 machine is equipped with the loading arm option, you must choose mode 780SB¼ instead of 680. The table will turn an extra 90° at the end of its cycle, which allows the bales to be loaded with the loading arm instead of the tractor.

ADJUSTMENT 5: Automatic stop when plastic film roll ripped or empty

Activate or deactivate this sensor mechanism on the plastic film stretcher with button 4 [yes / no]. Note that you must deactivate this command if you want to manually test the machine without a bale, because the machine will automatically stop after a quarter revolution due to lack of plastic film.

ADJUSTMENT 6: User language

Choose French or English with button 4

ADJUSTMENT 7: Remote control contrast

To accentuate or not the writing of the messages in the windows. This may be useful on a sunny day. Adjust using buttons 3 and 4 according to the instructions provided by the windows.

ADJUSTMENT 8: Zeroing the turntable

To reach this menu, alignment must first have been performed. If the position of the table before unloading needs to be better adjusted (the table in unloading position must be as perpendicular as possible to the bale wrapper frame), push button 3 or button 4: [-] or [+]. You will have a choice from -5 to +5. Press button 2 [Activate] and observe the result obtained. Readjust as necessary. See other details on page 26 (Unloading jam).

ADJUSTMENT 9: To associate the TAC-08, place the receiver on remote progr.

You must use button 4 [associate]. We have already explained this adjustment on page 20. Consult these instructions if necessary. If you get a new remote control, you must perform adjustment 9 and you will obtain a new code associating your remote control with your receiver.

5.3 Start and End Wrapping

Start



If you do not use the optional hydraulic unit, adjust your tractor at a flow rate of 8 GPM at 2000 PSI.

WARNING ! Make sure your bale counter has been properly programmed.

Once the table's latch has been removed, use the levers to lower the rear (1) and front (2) stabilizers (Figure 5.5), if applicable. Depending on the hardness of the ground, it is possible that after a dozen bales you will have to manually readjust the stabilizers to solidify your machine or keep it properly horizontal.

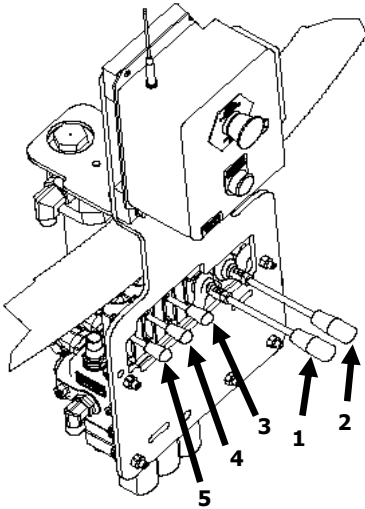

#	FONCTION
1 Rear	stabilizer
2 Fron	t stabilizer
3 Wrappi	ng lever
4 Table	rotation
5 T	ilt the table

Figure 5.5 Levers

First Bale

Take a round bale and place it in the center of the feed rollers, preferably on the side opposite the plastic film stretcher. Once the machine has been aligned, press button 3 [Wrap] in MENU #1 of your remote control. The wrapping process begins. Once the programmed revolutions are completed, the table tilts and the unloading platform slows the bale's descent (platform available as an option). This initiates the plastic film cutter (3), which cuts off the plastic film and holds the new end in its clamp. After bringing a new bale onto the rollers, you can take the first wrapped bale and put it in storage.

End Bale Wrapping

Do not forget to turn off your receiver and your remote control. Also shut off the fuel valve to prevent the gasoline from seeping into the engine oil. Once your batch of bales has been stored, take the time to check the airtightness of the plastic film on your bales. As necessary, seal the air leaks with tape so that fermentation will begin rapidly. Use the tape recommended by your plastic film supplier.

Levers (Figure 5.5)

Note: The table levers (table rotation (4), unloading (5), and plastic film cutter) (3) can be controlled manually to test the machine or to finish wrapping in case of a major electrical problem. We would also like to point out with the hydraulic unit and the stabilizers option, only one tractor is necessary for continuous wrapping to take place. The remote control of the 680 model also allows a single operator to perform all the wrapping operating.

5.4 Wrapping Without Remote Control

Start

Once your parameters have been entered into the computer, if, for an reason, you do not have a functional remote control, you can wrap bales using only your receiver. However, you cannot change the programming.

1. Activate the TAC-08 receiver by pulling the red START button. The blue WRAPPING button underneath will begin to blink regularly, which indicates that the machine is ready to be aligned.
2. Push the blue WRAPPING button and alignment of the bale wrapper will begin. When the blinking ceases and the blue button remains lit, the machine is ready to wrap. Place a bale on the table.
3. Once the bale has been placed on the table, push the blue button again and the bale will be wrapped. During this process, the button will blink. When the process is completed, the machine releases the bale and comes to a stop.
4. Place a new bale on the table, remove the first bale, and push the blue button again to wrap the new bale. And so on.

Error Messages

If a problem arises while the bale wrapper is being used without the remote control, the blinking of the blue WRAPPING button will change. (See the MENU S mode error messages section on page 25).

[Rotation sensor error / Rotation]

Characterized by a sequence of two (2) blinks followed by a pause.

[Zero setting sensor error / Zero setting]

Characterized by a sequence of three (3) blinks followed by a pause.

[Unloading sensor error / Unloading]

Characterized by a sequence of four (4) blinks followed by a pause.

If there is no blinking, check if the machine is blocked by the automatic stop due to a ripped or empty plastic film roll (adjustment 5)). If not, the list of MENUS mode error messages will give you more information.

6 Maintenance Procedures

Maintenance



Warning !

Before performing any maintenance operations on your machine, ensure that you are following the security precautions laid out in the safe maintenance and repair section: stop the engine (of the tractor or the unit), turn off the receiver, release hydraulic pressure, etc.

Grease Gun Lubrication

Your ANDERSON bale wrapper must be lubricated with a grease gun in the places indicated by the sticker (Figure 6.1).

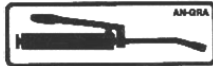

Figure 6.1 Grease gun lubrication



Note: The use of synthetic grease is highly recommended

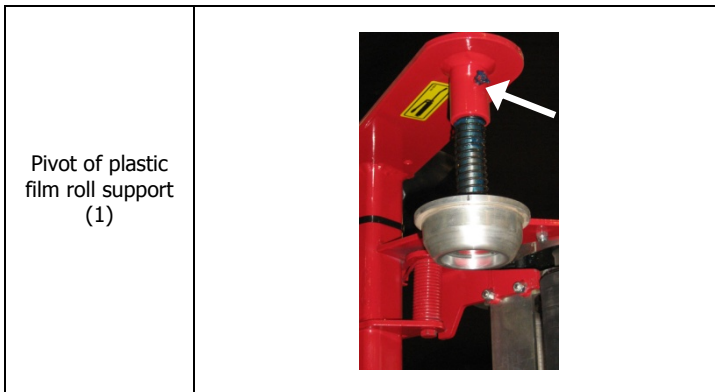

Greasing Frequency

Frequency	Greasing (number of grease cups)
Every 200 bales	Pivot of plastic film roll support (1) Central axle of turntable (1 on the top) Pivots of tilting table (2) Axles of the tilting cylinder (2) Axles of the unloading platform cylinder (2)* Pivot of the unloading arm (2)* Axles of the unloading arm cylinder (2)* Pivot of the unloading platform (4)*
Every 500 bales	Front and rear stabilizers (4)*
Every 1000 bales	Bearings of the two feed rollers of the belts (1 on each end, total of 4)

* Optional equipment



<p>Central axle of turntable (1 on the top)</p>	
<p>Pivots of tilting table (2)*</p>	
<p>Axles of the tilting cylinder (2)</p>	

<p>Axles of the unloading platform cylinder (2)*</p>	
<p>Pivot of the unloading arm (2)*</p>	
<p>Axles of the unloading arm cylinder (2)*</p>	

Pivot of the unloading platform (4)*



Front and rear stabilizers (2 grease cups each) and cylinder axles (2each)*

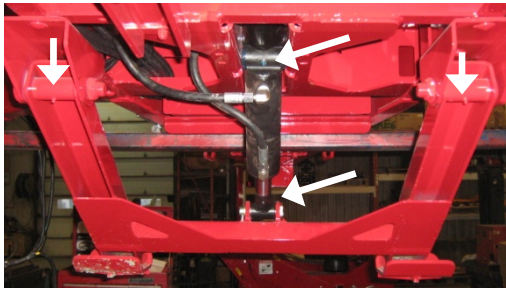

Bearings of the two feed rollers of the belts (1 on each end, total of 4)



Other Lubrication Points

The power transmission chains and other moving parts of the machine must be oiled or greased regularly or every 50 hours. This also applies to the 2 toothed wheels of the plastic film stretcher.



Figure 6.2 Other lubrication 1



Figure 6.3 Other lubrication 2 (through the hole in the guard)

Cleaning and Other Maintenance

Pay particular attention to the cleanliness of the plastic film cutter system. An accumulation of debris (hay, dust, string, etc.) can reduce its functionality. Regularly check the cutting condition of the blade.

Always keep the rollers and the gears of the plastic film stretcher free of all residue to prevent these parts from jamming, breaking, or tearing the plastic film. As necessary, wash the aluminium rollers with rubbing alcohol, penetrating oil, or paint thinner.

Also remove the hay that can get stuck in the axles and gears of the machine to not place needless strain on the hydraulic motor.

For the maintenance of the hydraulic unit, we recommend that you follow the Honda instruction manual for the maintenance of your engine. Check the oil level of the HONDA engine on each day of operation. The engine air filter must be checked each time you begin wrapping and cleaned as needed. As for changing the hydraulic oil, filter, and strainer, we recommend that you perform this maintenance every 5000 wrappings. It is a good idea to free the area around the gasoline engine of all flammable material. Add TDH oil.

Storage

To unhitch the machine, follow these steps:



Warning !

During unhitching operations, the operator is the only person authorized to be near the machine.

Before lowering the tractor to remove the hydraulic connections, and the electric cables, the operator must ensure that the machine is fully on the ground and stable. S/he must also engage the hand brake, turn off the tractor, and remove the key from the ignition switch.

- Secure the machine in a stable location.
- Use chocks to prevent the machine from moving while being unhitched from the tractor.
- Disconnect the hydraulic connections from the tractor.
- Disconnect the power cables.
- Remove the fixing pin and the security chain to rotate the jack.
- Replace the fixing pin and the security chain.
- Lift the pole with the jack.
- Remove the fixing pin and the security chain.



Warning !

Ensure that you have released the hydraulic pressure from the tractor's system to make disconnection and future reconnection easier.

- Remove the bale counter and store in a dry place.

It is preferable to keep the machine in a dry, covered place so that it will be in good condition when it is used again.

7 Troubleshooting: Problems and Solutions

Before calling a technician, examine your machine and consult the table below to find a solution. Attempt to isolate the problem to find out if it is a hydraulic or electrical problem by using the manual functions on the hydraulic valve. If you are still not able to solve the problem yourself, ask for help from the customer service department of your agricultural dealer.

Problems Pos	ossible Causes	Solutions
1. The engine of the hydraulic unit does not start.	The fuel valve is closed.	Open the fuel valve and start again.
	The gas tank is empty.	Put fuel in the tank and start again.
	The low engine oil sensor is activated.	Add oil to the engine and start again.
	The spark plug is clogged or defective	Clean the spark plug or change it.
	The engine is flooded because the fuel valve was not closed the previous day or during transportation.	Remove the spark plug, dry it out, dry out the cylinder by activating the starter crank. Put back the spark plug and start again.
	The fuse in the HONDA switch key box is burned out	Replace the fuse. (Figure 7.2)
2. The TAC-08C receiver does not work.	Defective power supply	Check the battery contacts and the electric connectors. Clean them if needed.
	A minimum of 12 V is necessary.	Check the performance of the battery and the alternator. Correct if necessary.
	The fuse(s) in the receiver case are burned out	Replace the defective fuses in the computer case. (Figure 5.2)
	The power cable fuse is burned out.	Replace the defective fuse. (Figure 7.1)
3. The TAC-08 remote control does not work (or is not associated).	The transmitter battery is dead.	Install the charger or work with the DC wire connected.
	The remote control is not associated.	See remote control association section. See procedure(Figure 5.2)

4. Table alignment cannot be performed.	The battery is too weak	Make sure you have 12 V by recharging or changing the battery.
	Defective electrical connections	Check the electrical connections (connectors on the hydraulic valves). See alignment procedure p. 22 and (Figure 7.3)
5. The turntable does not turn or turns slowly.	The hydraulic oil level is too low. Loss or lack of oil.	Check for oil leaks and breaks. Retighten or repair as necessary. Add hydraulic oil to the tank.
	Check if you still have 12 V.	Recharge or change the battery.
	The HONDA engine does not turn at the proper speed	The engine must be adjusted to 3600 revolutions/min.
6. The plastic film wrapping is unsatisfactory.	The plastic film breaks, develops holes, or tears during wrapping.	Check if the roll installed was damaged to be gin wi th and re place it if necessary.
		Check if hay o r so mething el se is inhibiting o r blocking the plasti c fi lm stretcher. Rem ove the o bject and clean the film stretcher. Check if all the rollers are turning freely.
		The film is to o soft because is has been in the s un f or to o long b efore being used. Install a cooler roll.
	The plastic film is not tight enough on the bale.	Check if the plastic film roll is properly installed.
Check if the parts of the plastic film stretcher a re in g ood c ondition a nd turn freely. Repair as needed.		
7. The plastic film cutter does not work well.	The plastic film cutter clamp does not hold onto the end of the plastic film.	The rubber stopper moves back too far on its adjustment bolt. Adjust the bolt. The stopper sprin g needs to be m ore tense. See procedure p. 18
8. The tilting table remains in raised or lowered position and the hydraulic engine continues to strain.	The table sensor in raised or lowered position does not work well.	Readjust the se nsor. Se e procedure and (Figure 5.4)

*It is im portant to always shut down the computer by pressing the red but ton before cutting the electrical current.

Reset Procedure

If a problem arises during operation and you determine that the problem is with the electrical system, the first step to take is to perform a complete reset of the TAC-09C receiver. See the following procedure:

- 1- Turn off the receiver (TAC-08C) by pushing the red button on the front of the receiver case.
- 2- Open the receiver case.
- 3- Push and **hold down the blue button** (green on certain models) found on the receiver case.
- 4- Activate the receiver by pulling the red button on the receiver case **all while holding down the blue button.**
- 5- Look at the interior of the receiver and you will see a black button (operation mode, see (Figure 5.2)) located in the upper half of the receiver. Press this button two times until the light located above the button faces the "mode test" line.
- 6- Release the blue button.
- 7- Turn off the receiver by pushing the red button on the case of the receiver.
- 8- Wait 5 seconds.
- 9- Perform an alignment procedure on the machine by following the instructions and turn off the receiver (P. 22). Repeat this procedure 3 times in a row (alignment) (Alignment + Turning off the computer).
- 10- Once all 3 alignments have been performed, test the system by performing a wrapping dry run by pressing the blue button on the receiver case. (Note: if you perform a wrapping test without a bale (a dry run), make sure that the plastic film detector is deactivated (see adjustment 5).

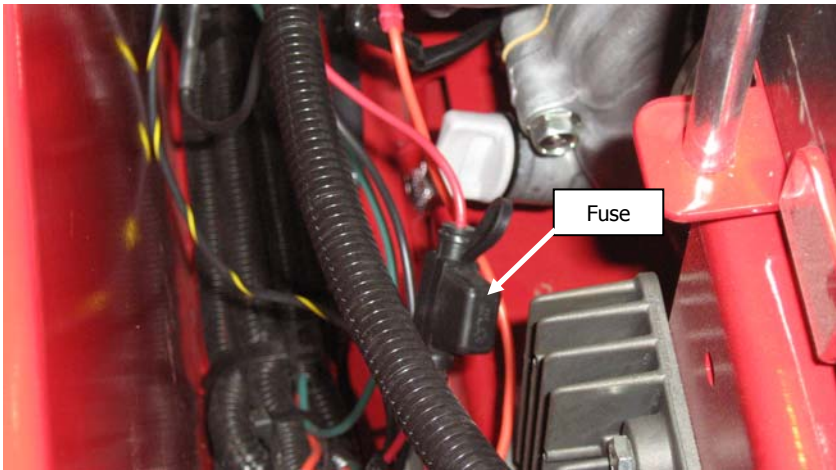

Figure 7.1 Fuse cables

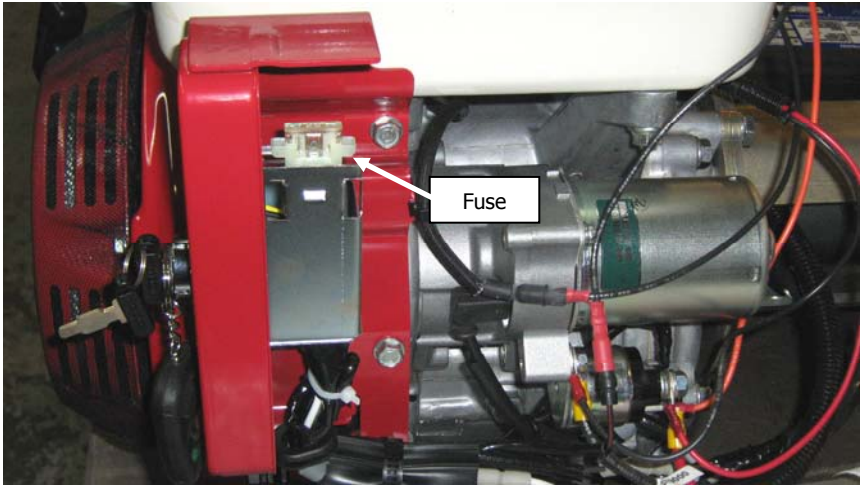

Figure 7.2 Starter fuse

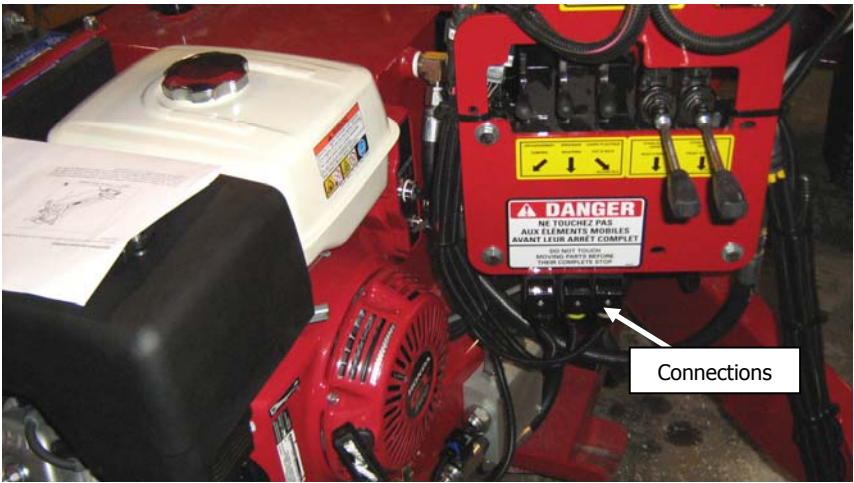

Figure 7.3 Electrical connections

8 Optional Equipment

Stabilizers

Activated by hydraulic cylinders and controlled by manual controls at the front of the machine, these two pieces of equipment improve the stability of the bale wrapper. They are equipped with security valves (lock valves) to prevent inadvertent movement of stabilizers or the feet from collapsing, whether the machine is turned on or not. The stabilizer option and the hydraulic unit option make it possible to completely detach the bale wrapper and to function independently, one tractor is required to handle bales.

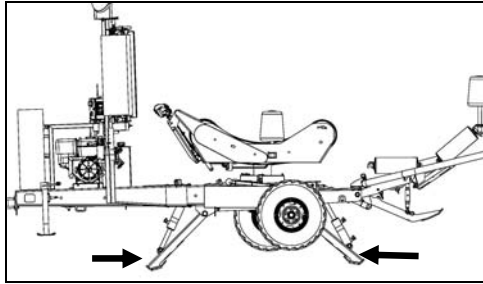

Figure 8.1 Stabilizers

Modifying Gears to Reduce Stretch Ratio

It is possible to modify the standard stretch ratio (65%) by changing the gears of the plastic film stretcher and thereby obtain a ratio of approximately 55%. Contact your dealer to obtain this accessory.

Bale Loading Arm and Plastic Film Roll Support

As an option, a loading arm can be installed on the bale wrapper **only at Anderson manufacture**. This arm makes it possible to load bales directly onto the bale wrapper without using a frontal loader.

1. The loading arm option is always sent with extension cables to control the wrapper from the tractor seat and a rack to carry two extra rolls of plastic.
2. For loading the bale, the turntable must be parallel to the loading arm.
3. The loading arm is equipped with a safety device to prevent collisions with the turntable and error operations. The loading arm must be dropped halfway between the turntable and the ground so that the table can rotate and wrap.
4. Adjustment of the loading arm :
Fork outer arm adjusts to different bale diameter. An adjustable backstop allows you to charge balls of 4 or 5 feet (1.2 m or 1.5m) wide and filed on the center of the turntable.
5. Transport



WARNING!

To transport the wrapper equipped with a loading arm, install the safety pin (1) that keeps the loading arm upright.

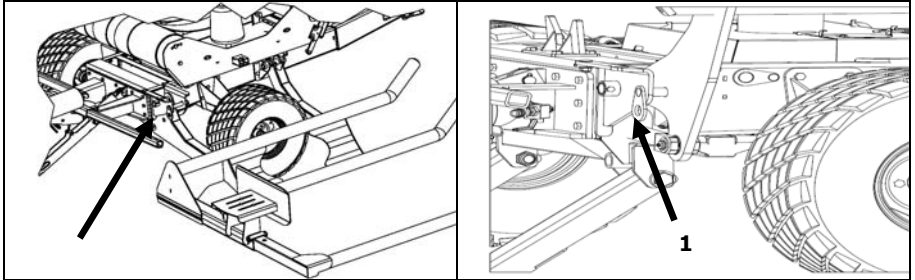

Figure 8.2 Bale Loading Arm

Installing the Bale Loading Arm Control

For the connections, refer to the parts book in section (electrical diagram of loading arm). Look at the following illustrations to place the connections. Connecting the battery (Figure 8.3), Connecting the controller (Figure 8.4), Connecting the valve (Figure 8.5), and Controller support (Figure 8.6)



Figure 8.3 Battery connection



Figure 8.4 Controller connection



Figure 8.5 Valve connection



Figure 8.6 Controller support

Bale Unloading Platform (D)

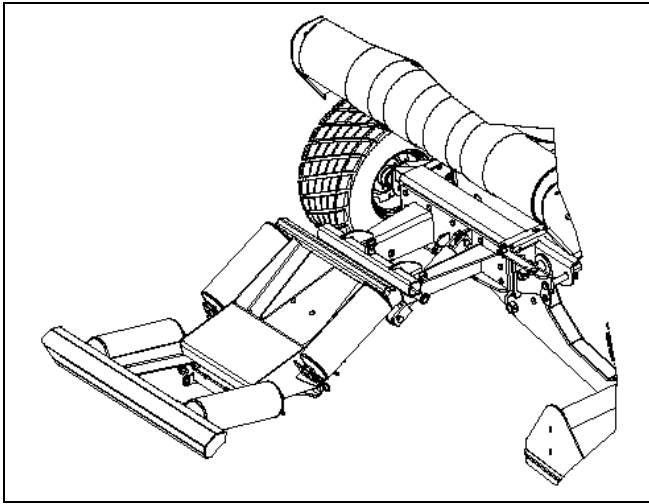

Figure 8.7 Bale unloading platform D

This optional unloading ramp makes it possible to gently discharge wrapped bales behind the bale wrapper. This system is composed of a rigid platform, a hydraulic cylinder, and a maintenance-free nitrogen cylinder.

Bale Unloading Platform (D3)

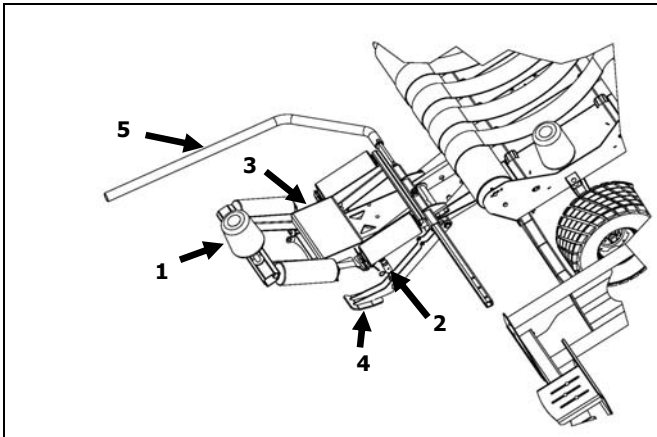

Figure 8.8 Bale unloading platform D3

This optional equipment makes it possible to bring the bales to a vertical position and set them down on the flat side.

Additionally, this unloading platform makes it possible to turn bales on one side or the other according to the preference of the user. To make this change, the operator need only place the barrier (6) on top of the platform, the foot (4), the support roller (1), and the retaining bar (5) on the other side of the unloading platform. The same attachment points are situated on each side of the platform to facilitate the change.



WARNING !

For transport, it is necessary to manually retract the retaining bar (2) (Figure 8.8).

With the D3 option, it is possible to gently discharge bales on the cylindrical side (without rotation). The operator need only raise the foot, remove the support roller (1), and ensure that the 2 platform barriers are installed to limit movement.



Installation of the three position unloading platform (D3)

Here are the steps to install the unloading platform D3 from the unloading platform D :

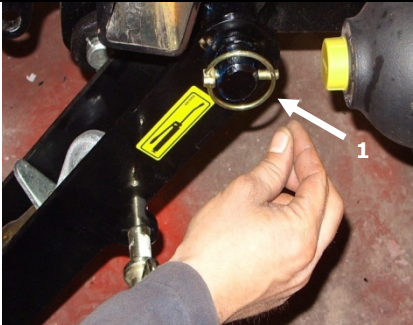
Installation of the foot

<p>Sand the shaft.</p>	
<p>Slide the foot on the shaft and lock in place with the linchpin. (1).</p>	

Attaching the retaining arm on the support

<p>Install the support of the arm.</p>	
<p>Place the support on the dumping unit and bolt into place. Holes on the dumper are predrilled from the factory.</p>	

Installation of the retaining arm

<p>Insert the fixed part of the arm into the support.</p>	
---	--

You can now attach the "L" shaped bar to the straight bar. (4 bolts)



Installation of the cone shaped roller

Remove the deflector at the end of the dumper to reveal the placement holes for the cone shaped roller.



Place the cone shaped roller on the same side as the foot as you will be bumping the bale to the opposite side.



This procedure is for if you are dropping the bale to the left side. The same procedure is used when dumping to the right side but the foot and cone roller will be placed on the other side of the machine. Also the "L" shaped retaining arm must be inserted opposite to the procedure.

Charging the accumulator

When the unloading platform does not go back to its position, you must correct the pressure in the accumulator to a pressure ranging from 1000 to 1200 lbs. A too low pressure will not lift the unloading platform to its position and a too high pressure will not allow the bale to dump from the unloading platform.

1. Remove the handle (1)
2. Turn the lock washer (2) to enable the handle to turn and open the ball valve (4).
3. Replace the handle (1).
4. Connect a hydraulic pump at the male quick connect (3).
5. Open the ball valve (4). The unloading platform will go down.
6. Put hydraulic oil to achieve a pressure of 1000 lbs. Press on the unloading platform for to verify if he goes back to its position and adjust the pressure as required.
7. Close the ball valve (4).
8. Remove the handle (1).
9. Turn the lock washer (2) that its lock the handle.
10. Replace the handle (1).

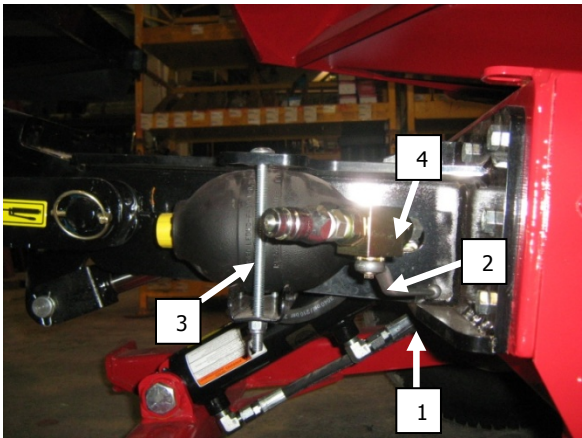

Figure 8.9 Accumulator of the unloading arm

If using a tractor for this procedure we recommend that you put a relief valve between the wrapper and the tractor. This way you can fully open the oil from the tractor and regulate it with the relief valve.

Double Roll Plastic Unit

The double roll option allows to install two plastic film rolls on the plastic film roll stretcher, thereby making it possible to apply a double layer of plastic with each rotation of the table. With this option, wrapping time will be decrease by almost half, because two layers of plastic are applied simultaneously



Figure 8.10 Double stretch roll

Start-Up Procedures

When you receive your new ANDERSON equipment:

Stationary mode:

- 1- Attach the bale wrapper to the tractor or stabilize the machine with the stabilizers and start the engine HONDA.
- 2- Activate the receiver by pulling the red button. The blue light on the receiver case will blink. Push the activation button on the lower left of the transmitter. The display will appear and will show menu 4 (alignment).
- 3- Remove the table latch on the bale wrapper (Figure 2.1). The engine must be stop.
- 4- Align the table (Page 22).
- 5- When the engine is hot, you can also start the HONDA motor using the remote control only. To do this, activate the receiver and the remote control without starting the HONDA engine with the key (nonetheless, the key must be placed in "ON" position). The remote control display will show menu 5. Push button 4 and the engine will start. The system can automatically attempt (up to 3 times) to start the HONDA engine. When the engine has started, menu 1 will be displayed on the remote control. Press button 3 to access menu 4, then press button 4 to perform the alignment procedure.
- 6- At the end of the alignment procedure, carefully observe the position of the table. The table in unloading position must be as perpendicular as possible to the bale wrapper frame. If this is not the case, see adjustment procedure 8 (P.27).
- 7- Install a plastic film roll (Figure 4.1). Insert the edge of the plastic film in the clamp of the plastic film cutter. Pull the corresponding lever to hold the film (Figure 5.5) (Note: if you perform a wrapping test without a bale (dry run), ensure that the plastic film detector is deactivated (see adjustment 5) (P.27).
- 8- Place a bale on the table, centered between the support rollers.
- 9- The bale wrapper's default wrapping conditions are: 18 wrapping revolutions and 24 revolutions/min. If you want to modify these parameters, refer to the adjustment mode section (P.27).
- 10- Press the blue button or use the remote control once you have entered your desired programming (number of revolutions and speed of rotation, see adjustment mode section) and the wrapping process will begin. Once the desired number of revolutions is completed, the bale wrapper table will come to a stop perpendicular to the frame. Finally, the table will rise up to discharge the bale and come back down again.

Field mode:

- 1- Remove the table latch on the bale wrapper (Figure 2.1).
- 2- Align the table (Page 22).
- 3- When the engine is hot, you can also start the HONDA motor using the remote control only. To do this, activate the receiver and the remote control without starting the HONDA engine with the key (nonetheless, the key must be placed in "ON" position). The remote control display will show menu 5. Push button 4 and the engine will start. The system can automatically attempt (up to 3 times) to start the HONDA engine. When the engine has started, menu 1 will be displayed on the remote control. Press button 3 to access menu 4, then press button 4 to perform the alignment procedure.
- 4- At the end of the alignment procedure, carefully observe the position of the table. The table in unloading position must be as perpendicular as possible to the bale wrapper frame. If this is not the case, see adjustment procedure 8 (P.27).

- 5- Install a plastic film roll (Figure 4.1). Insert the edge of the plastic film in the clamp of the plastic film cutter. Pull the corresponding lever to hold the film (Figure 5.5) (Note: if you perform a wrapping test without a bale (dry run), ensure that the plastic film detector is deactivated (see adjustment 5) (P.27).
- 6- Enable the tractor hydraulic system or start the hydraulic unit.
- 7- Place a bale on the table, centered between the support rollers.
- 8- The bale wrapper's default wrapping conditions are: 18 wrapping revolutions and 24 revolutions/min. If you want to modify these parameters, refer to the adjustment mode section (P.27).
- 9- Press the blue button or use the remote control once you have entered your desired programming (number of revolutions and speed of rotation, see adjustment mode section) and the wrapping process will begin. Once the desired number of revolutions is completed, the bale wrapper table will come to a stop perpendicular to the frame. Finally, the table will rise up to discharge the bale and come back down again.



Parts manual

ROUND BALE WRAPPER RB680

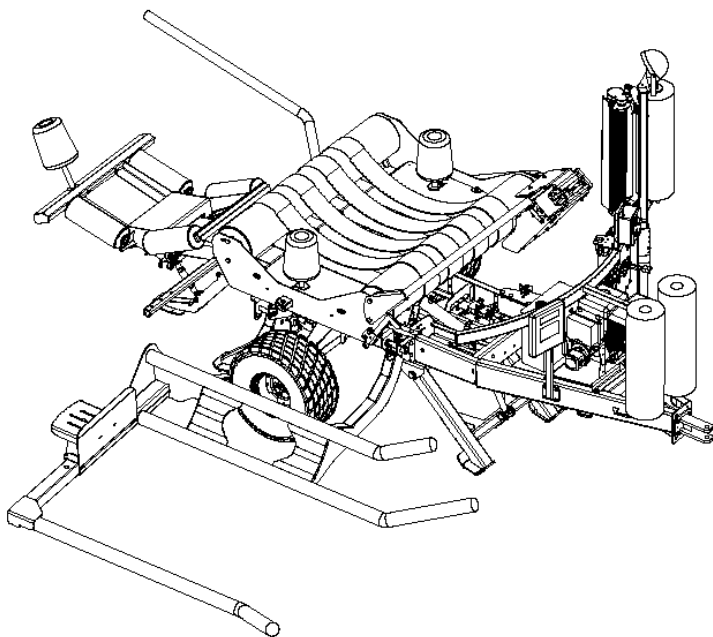

ALWAYS KEEP THIS MANUAL WITH THE WRAPPER

Content

1 – Main Frame	P. 2
2 – Plastic Roller Frame, Coupling Hand and Tongue	P. 3
3 – Axle	P. 4
4 – Roll, Shield, and Valve	P. 5-10
5 – Stretcher Support Arm	P. 11
6 – Stretcher Support	P. 12
7 – Stretcher	P. 13
8 – Power Unit	P. 14
9 – Dumping Table	P. 15-16
10 – Rotary Table	P. 17
11 – Cut and Hold	P. 18
12 – Central Hub	P. 19
13 – Loading Arm	P. 20-22
14 – Stabilizer	P. 23
15 – Drop Off	P. 24-26
16 – Hydraulic Diagram	P. 27-34
17 – Loading Arm Electrical Diagram	P. 35
18 – RB-680 Electrical Diagram	P. 36

For any parts order, please use the parts manual to find the item(s) you need and contact your dealer to order it or contact us directly at :

ANDERSON GROUP

5125 de la Plaisance
Chester ville (Québec)
CANADA G0P 1J0

Fax : (819) 382-2643
Email : service@grpanderson.com

Visit our website → www.grpanderson.com

1 - FRAME

PARTS LIST			
ITEM	QTY	PART	DESCRIPTION
1	1	22300-1	FRAME
2	2	223001	HOSE HOLDER
3	7	500444	CARRIAGE BOLT
4	5	223002	HOSE HOLDER
5	1	466000	PRESSURE LIMITER
6	10	501030	NYLON NUT
7	4	500014	BOLT
8	2	223003	PIVOT AXLE
9	2	500443	CARRIAGE BOLT
10	2	501022	FLANGE NUT
11	2	465063	HYDRAULIC VALVE
12	1	501031	NYLON NUT
13	1	500334	BOLT
14	1	223005-1	VALVE SUPPORT
15	9	501032	NYLON NUT
16	2	500084	BOLT
17	6	500016	BOLT
18	1	500044	BOLT
19	5	451172	HYDRAULIC FITTING
20	2	451355	HYDRAULIC FITTING
21	2	466989	VALVE
22	6	451260	HYDRAULIC FITTING
23	2	451171	HYDRAULIC FITTING
24	1	450972	HYDRAULIC FITTING
25	2	451261	HYDRAULIC FITTING
26	1	501057	HALF NYLON NUT

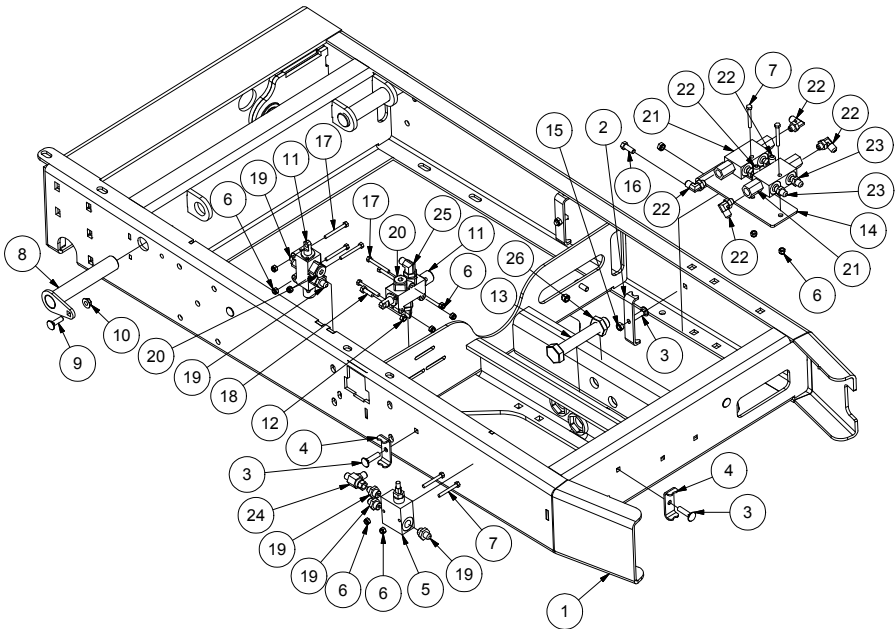

PLASTIC ROLLER ROLLER SUPPORT

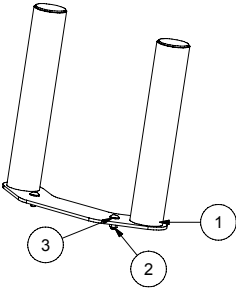

PARTS LIST			
ITEM	QTY	PART	DESCRIPTION
1	2	224082-1	PLASTIC ROLLER SUPPORT
2	2	501022	FLANGE NUT
3	2	500442	CARRIAGE BOLT

COUPLING HAND

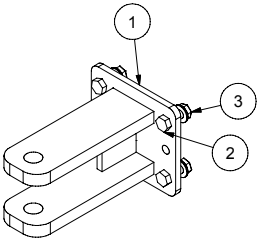

PARTS LIST			
ITEM	QTY	PART	DESCRIPTION
1	1	223076	COUPLING HAND
2	4	500177	BOLT
3	4	501024	FLANGE NUT

TONGUE

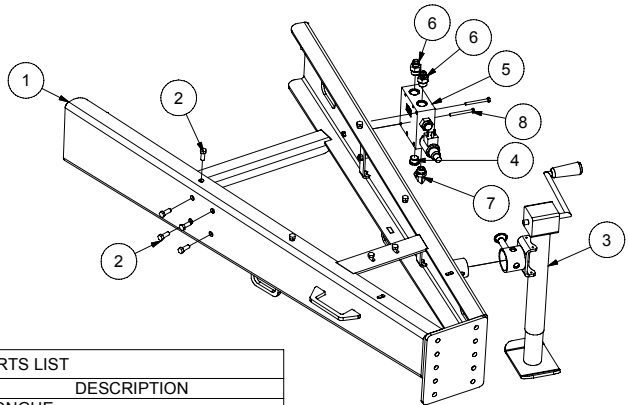

PARTS LIST			
ITEM	QTY	PART	DESCRIPTION
1	1	223077-1	TONGUE
2	10	500084	BOLT
3	1	322457	JACK
4	1	451355	HYDRAULIC FITTING
5	1	465903	VALVE
6	2	451179	HYDRAULIC FITTING
7	1	451265	HYDRAULIC FITTING
8	2	500017	BOLT

PARTS LIST			
ITEM	QTY	PART	DESCRIPTION
1	1	223084	DOMPING TABLE LOCK
2	1	500088	BOLT
3	5	501022	FLANGE NUT
4	4	500443	CARRIAGE BOLT
5.1	2	481400	HUB
5.2	2	320002	COTTER PIN
5.3	2	501076	CASTLE NUT
6	13	501024	FLANGE NUT
7	9	500175	BOLT
8	4	500501	CARRIAGE BOLT
9	1	223080-1	COMPLETE RIGHT AXLE
10	1	223081-1	COMPLETE LEFT AXLE
11	2	481604	TIRE AND RIM

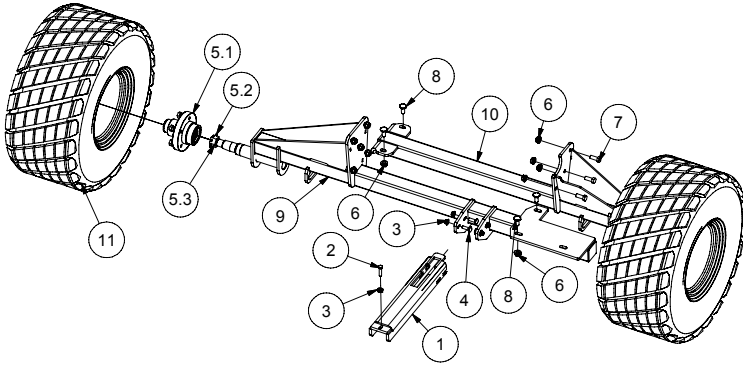

PARTS LIST			
ITEM	QTY	PART	DESCRIPTION
1	1	481400	HUB
2	1	303035	BEARING
3	1	303036	BEARING
4	1	303037	ROLLING BEARING CAGE
5	1	303034	BEARING
6	1	303077	SEAL
7	1	481000	DUST CAP
8	5	507010	WHEEL BOLT

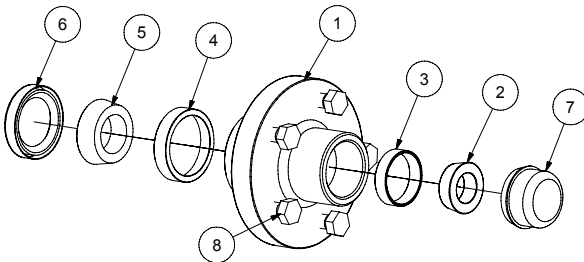

4 - ROLL, SHIELD, VALVE

PARTS LIST			
ITEM	QTY	PART	DESCRIPTION
1	1	223026	ROLL AXLE
2	2	320006	RETAINING RING
3	1	320039	HITCH PIN
4	1	325107	CAP
5	1	224027	SUPPORT ROLLER
6	2	303045	BEARING

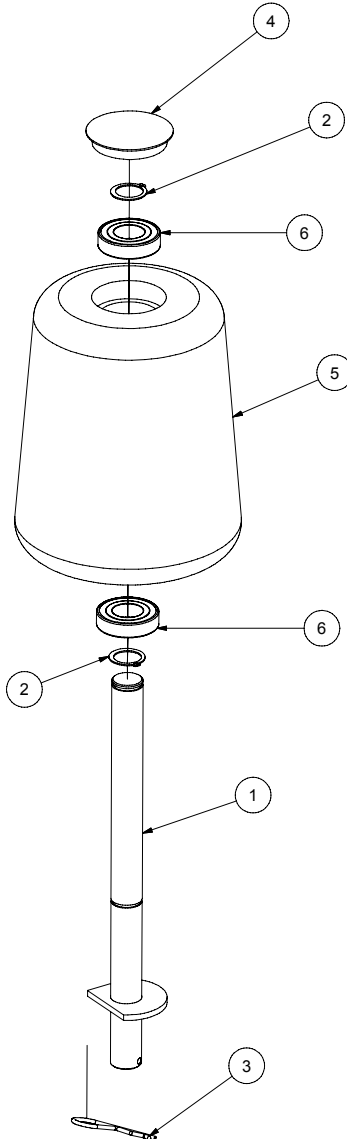

4 - ROLL, SHIELD, VALVE

PARTS LIST			
ITEM	QTY	PART	DESCRIPTION
1	1	223027	SHIELD
2	3	507006	SELF-DRILLING SCREW
3	1	325109-1	MANUAL BOX
4	1	325120	MANUAL CASE
5	2	SEE NEXT PAGE	HYDRAULIC VALVE
6	13	501031	NYLON NUT
7	11	500048	BOLT
8	13	502014	FLAT WASHER
9	1	SEE NEXT PAGE	HYDRAULIC VALVE AND FITTING
10	1	315002	RECEIVER
11	1	315017	TRANSMITTER
12	2	209604	INSULATOR
13	6	507029	SCREW
14	2	500050	BOLT
15	2	481009	PLASTIC CAP
16	1	223192	FILTER SUPPORT
17	1	SEE NEXT PAGE	HIGH PRESSURE FILTER AND FITTING

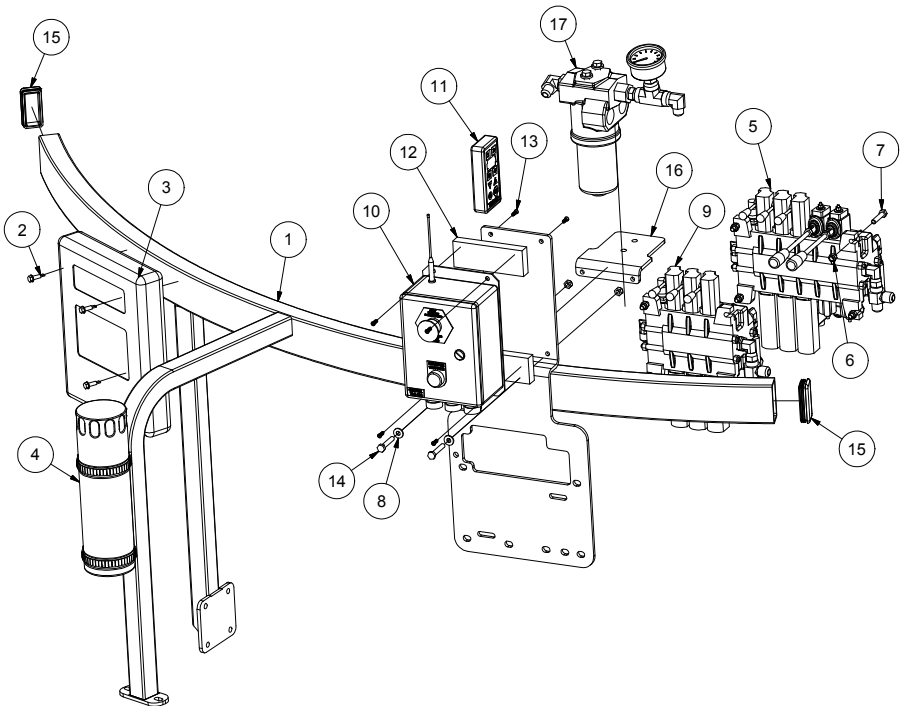

4 - ROLL, SHIELD, VALVE

PARTS LIST			
ITEM	QTY	PART	DESCRIPTION
1	1	465981	HYDRAULIC VALVE
2	6	451227	HYDRAULIC FITTING
3	1	451262	HYDRAULIC FITTING
4	3	502014	FLAT WASHER
5	3	500048	BOLT
6	3	501031	NYLON NUT
7	2	451265	HYDRAULIC FITTING
8	1	450973	HYDRAULIC FITTING
9	1	450972	HYDRAULIC FITTING
10	1	450711	HYDRAULIC FITTING
11	1	465883	CHECK VALVE
12	2	450994	HYDRAULIC FITTING
13	1	465504	VALVE
14	1	450542	HYDRAULIC FITTING
15	1	451355	HYDRAULIC FITTING
16	1	465913	CHECK VALVE

680-WITHOUT STABILIZER

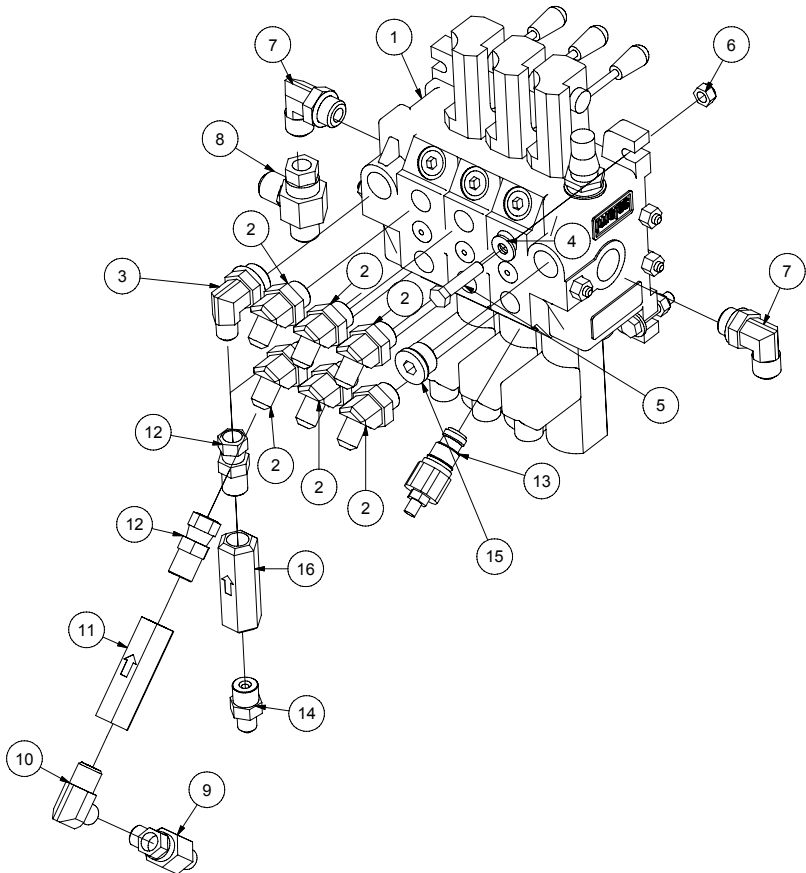

4 - ROLL, SHIELD, VALVE

PARTS LIST			
ITEM	QTY	PART	DESCRIPTION
1	1	465982	HYDRAULIC VALVE
2	10	451227	HYDRAULIC FITTING
3	1	451262	HYDRAULIC FITTING
4	4	501031	NYLON NUT
5	4	500048	BOLT
6	4	502014	FLAT WASHER
7	1	451355	HYDRAULIC FITTING
8	2	451265	HYDRAULIC FITTING
9	1	450973	HYDRAULIC FITTING
10	2	450994	HYDRAULIC FITTING
11	1	450542	HYDRAULIC FITTING
12	1	450972	HYDRAULIC FITTING
13	1	450711	HYDRAULIC FITTING
14	1	465883	CHECK VALVE
15	1	465504	VALVE
16	1	465913	CHECK VALVE

680-WITH STABILIZER

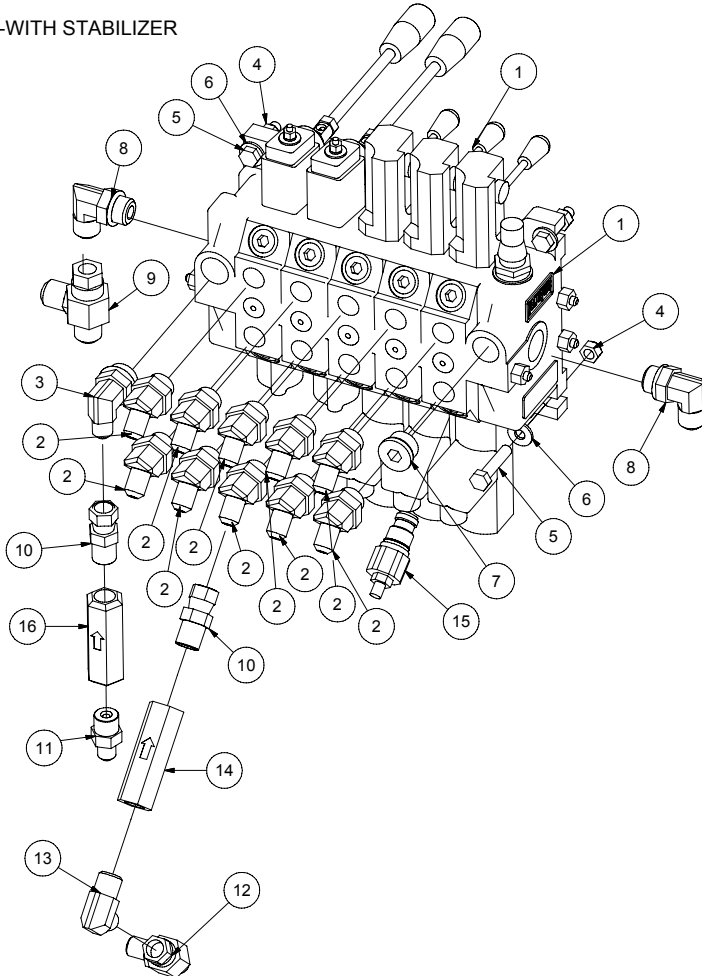

4 - ROLL, SHIELD, VALVE

PARTS LIST			
ITEM	QTY	PART	DESCRIPTION
1	8	451227	HYDRAULIC FITTING
2	1	451262	HYDRAULIC FITTING
3	2	451265	HYDRAULIC FITTING
4	1	450973	HYDRAULIC FITTING
5	1	450972	HYDRAULIC FITTING
6	1	450711	HYDRAULIC FITTING
7	1	465883	CHECK VALVE
8	2	450994	HYDRAULIC FITTING
9	1	465504	VALVE
10	1	450542	HYDRAULIC FITTING
11	1	451355	HYDRAULIC FITTING
12	1	465913	CHECK VALVE
13	1	465921	ELECTRIC VALVE

680-WITH LOADING ARM

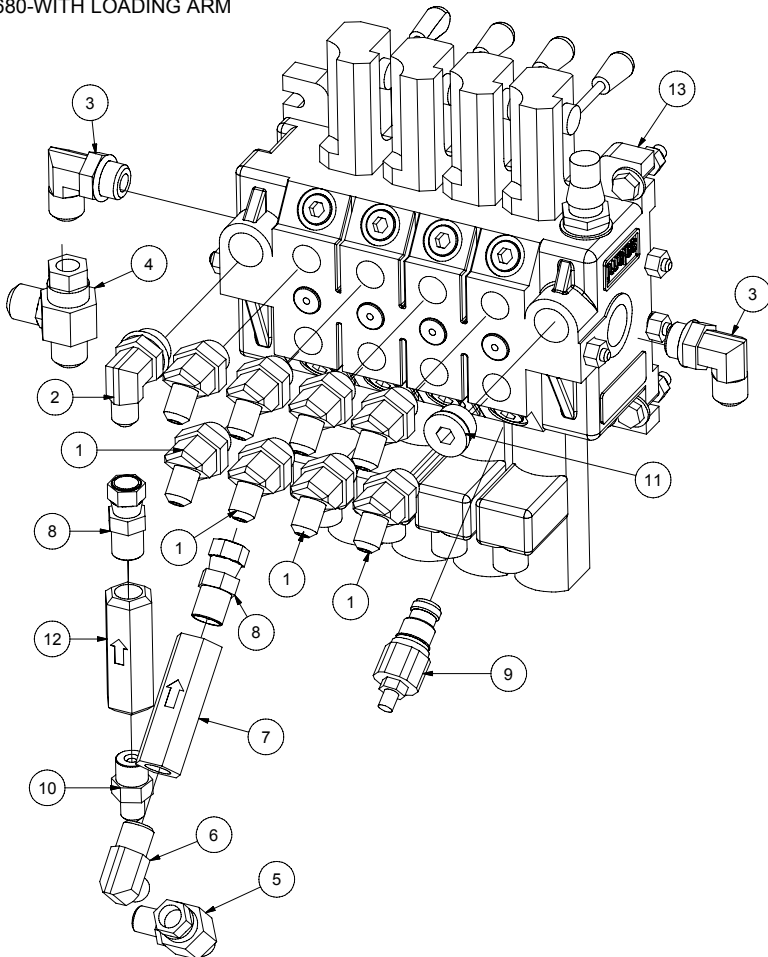

4 - ROLL, SHIELD, VALVE



PARTS LIST			
ITEM	QTY	PART	DESCRIPTION
1	1	451267	HYDRAULIC FITTING
2	1	451126	HYDRAULIC FITTING
3	1	450008	HYDRAULIC FITTING
4	1	450243	HYDRAULIC FITTING
5	1	450716	HYDRAULIC FITTING
6	1	450024	HYDRAULIC FITTING
7	1	470010	PRESSURE GAUGE
8	1	469995	CATRIDGE
9	1	470018	FILTER
10	2	500084	BOLT
11	2	502045	LOCK WASHER

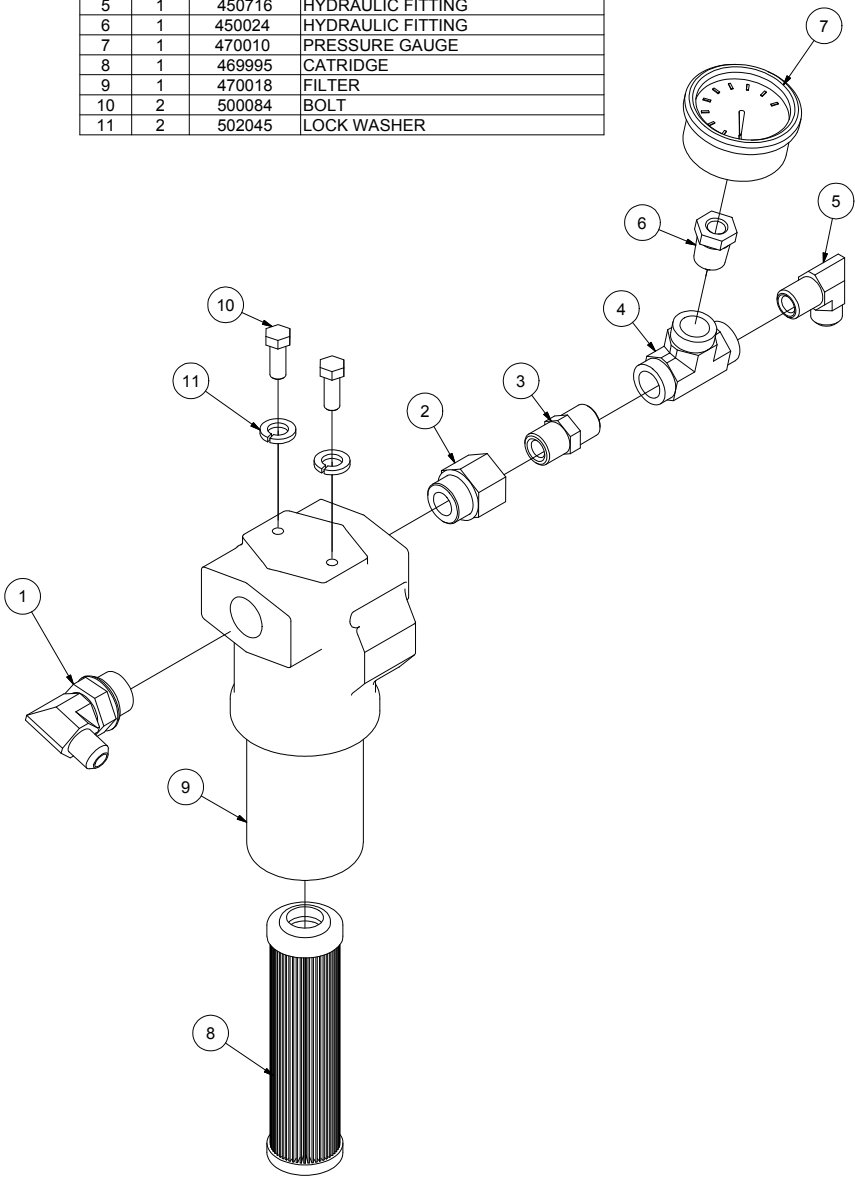

5 - STRETCHER SUPPORT

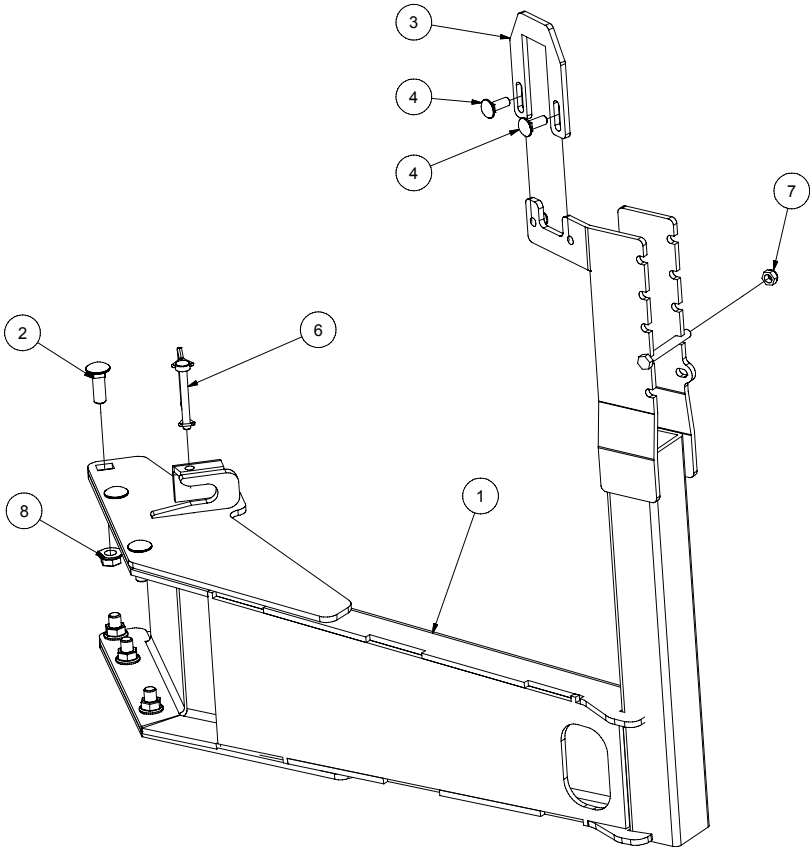

PARTS LIST			
ITEM	QTY	PART	DESCRIPTION
1	1	223067	ARM
2	6	500502	CARRIAGE BOLT
3	1	223068	REINFORCMENT
4	2	500442	CARRIAGE BOLT
6	1	320021	LOCK
7	3	501032	NYLON NUT
8	6	501024	FLANGE NUT
23	1	500099	BOLT

6 - STRETCHER POST

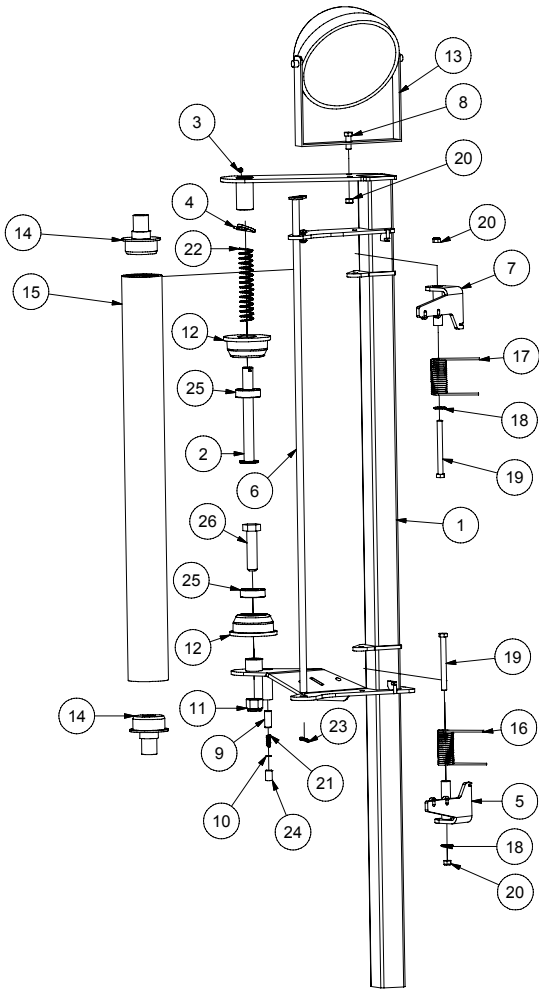

PARTS LIST				PARTS LIST			
ITEM	QTY	PART	DESCRIPTION	ITEM	QTY	PART	DESCRIPTION
1	1	224076	STRETCHER'S POST	14	2	306018	AXLE
2	1	224077	SHAFT	15	1	210676	RUBBER ROLLER
3	1	322299	GREASE FITTING	16	1	304007	SPRING
4	1	320039	HITCH PIN	17	1	304008	SPRING
5	1	224078	SPRING HOLDER	18	2	502004	FLAT WASHER
6	1	224079	ROD	19	2	500104	BOLT
7	1	224080	SPRING HOLDER	20	3	501032	NYLON NUT
8	1	500084	BOLT	21	1	304023	SPRING
9	1	224081	BRAKE TEFLON	22	1	304009	SPRING
10	1	502001	FLAT WASHER	23	1	320002	PIN
11	1	501036	NYLON NUT	24	1	507036	ALLEN SET SCREW
12	2	224082	ROLLER SUPPORT	25	2	303012	BEARING
13	1	319880	WORK LIGHT	26	1	500289	BOLT

7 - STRETCHER

PARTS LIST

ITEM	QTY	PART	DESCRIPTION
1	2	224067	ROLLING BEARING CAGE
2	1	279102	GEAR
3	1	279100	GEAR
4	2	224068	SPACER
5	2	500017	BOLT
6	1	224065	LOWER BRACKET
7	1	224066	UPPER BRACKET
8	1	224070	ROD
9	5	500004	BOLT
10	2	224067	ROLLING CAGE
11	1	224071	SHIELD
12	8	501030	NYLON NUT
13	1	224072	SENSOR BRACKET
14	1	224073	SENSOR BRACKET
15	4	500006	BOLT
16	1	224075	PLASTIC SHIELD
17	2	320022	KEY
18	2	501020	FLANGE NUT
19	1	322299	GREASE FITTING
20	1	315056	SENSOR
21	2	501022	FLANGE NUT
22	4	303018	BEARING
23	2	315007	SENSOR NUT
24	2	502080	LOCK WASHER
25	2	279004	ROLL
26	1	279103	GEAR
27	1	279104	GEAR

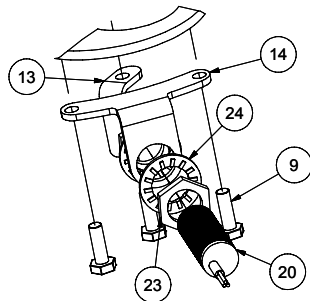
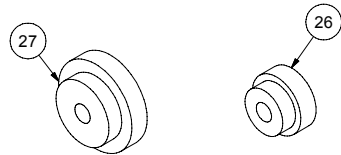
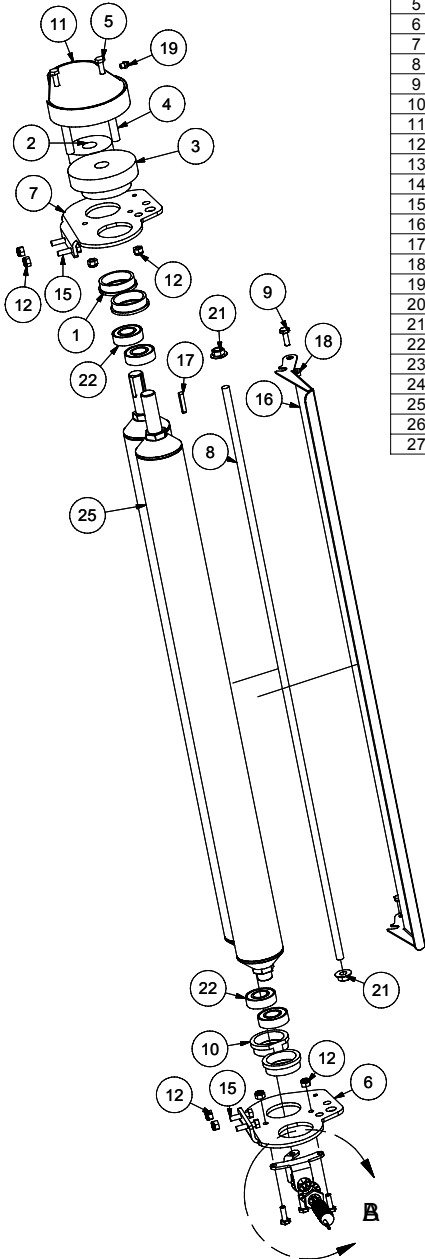

DETAIL B

OPTION

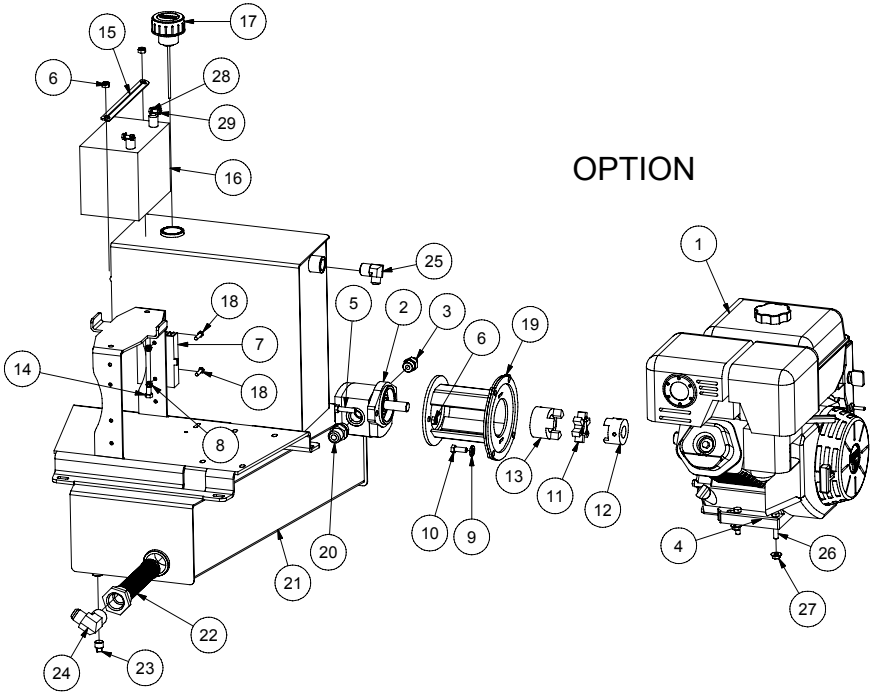

PARTS LIST

ITEM	QTY	PART	DESCRIPTION
1	1	610006	ENGINE
2	1	468495-468002	PUMP
3	1	451179	HYDRAULIC FITTING
4	4	502004	FLAT WASHER
5	2	500088	BOLT
6	4	501032	NYLON NUT
7	1	605009	VOLTAGE REGULATOR
8	4	501030	NYLON NUT
9	4	502045	LOCK WASHER
10	4	500084	BOLT
11	1	322020	INSERT
12	1	322050	COUPLING
13	1	322042	COUPLING
14	2	500114	BOLT
15	1	224110	BATTERY HOLDER
16	1	470113	BATTERY
17	1	470112	PLUG
18	2	500006	BOLT
19	1	322008	PUMP ADAPTER
20	1	451190	HYDRAULIC FITTING
21	1	224108	TANK
22	1	470990	STRAINER
23	1	470117	PLUG
24	1	450725	HYDRAULIC FITTING
25	1	450717	HYDRAULIC FITTING
26	4	500092	BOLT
27	4	501022	FLANGE NUT
28	2	501020	FLANGE NUT
29	2	500004	BOLT

9 - DUMPING TABLE

PARTS LIST				PARTS LIST			
ITEM	QTY	PART	DESCRIPTION	ITEM	QTY	PART	DESCRIPTION
1	2	224188-1	FRAME DUMPING TABLE	17	4	501049	NYLON NUT
2	2	322299	GREASE FITTING	18	1	469147	HYDRAULIC MOTOR
3	2	501034	NYLON NUT	19	2	450710	HYDRAULIC FITTING
4	4	315007	SENSOR NUT	20	2	451173	HYDRAULIC FITTING
5	3	500004	BOLT	21	2	507003	ALLEN SET SCREW
6	1	223016	SHIELD (REAR)	22	1	210629	WASHER
7	1	223017	SHIELD (FRONT)	23	4	502080	LOCK WASHER
8	1	223018	DOOR	24	2	315056	SENSOR
9	1	501030	NYLON NUT	25	2	501020	FLANGE NUT
10	1	500044	BOLT	26	4	500348	BOLT
11	2	500180	BOLT	27	1	320032-1	HITCH PIN
12	1	315020-1	ENCODER	28	1	501037	NYLON NUT
13	1	223169	ENCODER POSITIONER	29	2	500084	BOLT
14	1	223086	GEAR	30	2	502045	LOCK WASHER
15	1	507005	ALLEN SET SCREW	31	1	222053	SHUTTER
16	1	300513	GEAR	32	1	500333	BOLT

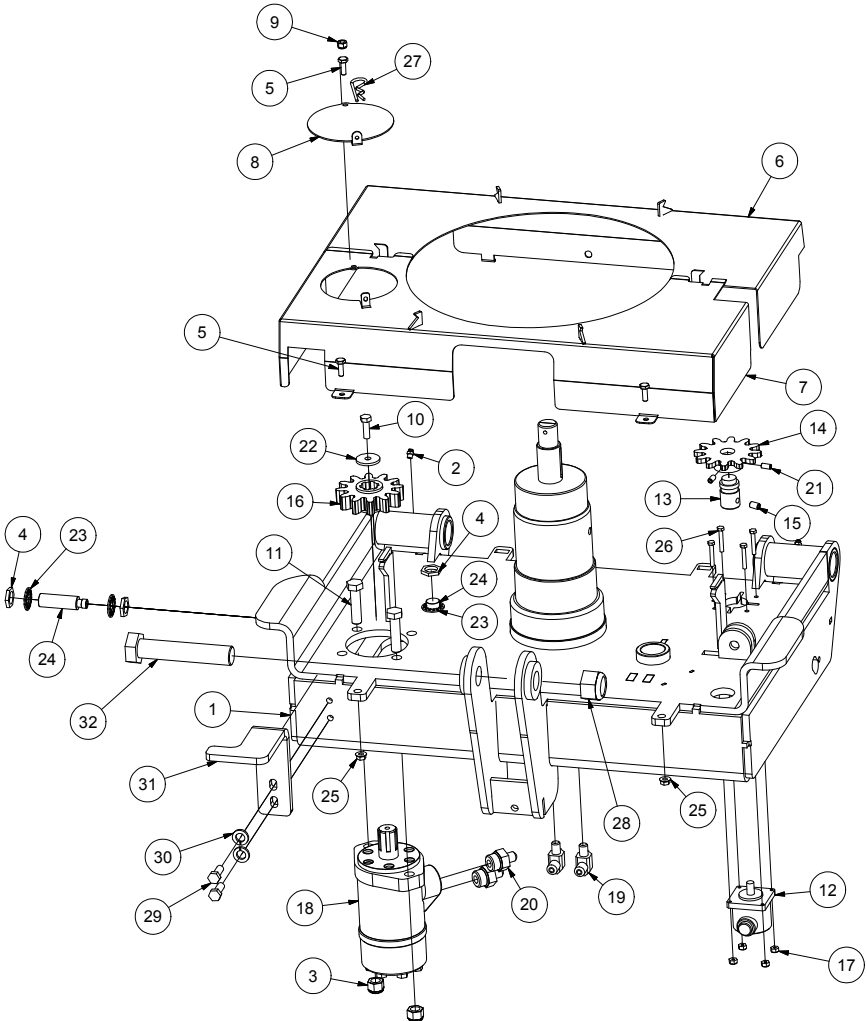

9 - DUMPING TABLE

PARTS LIST			
ITEM	QTY	PART	DESCRIPTION
1	2	450712	HYDRAULIC FITTING
2	1	467029	HYDRAULIC CYLINDER
3	1	450543	HYDRAULIC FITTING
4	1	465878	CHECK VALVE
5	2	322295	GREASE FITTING

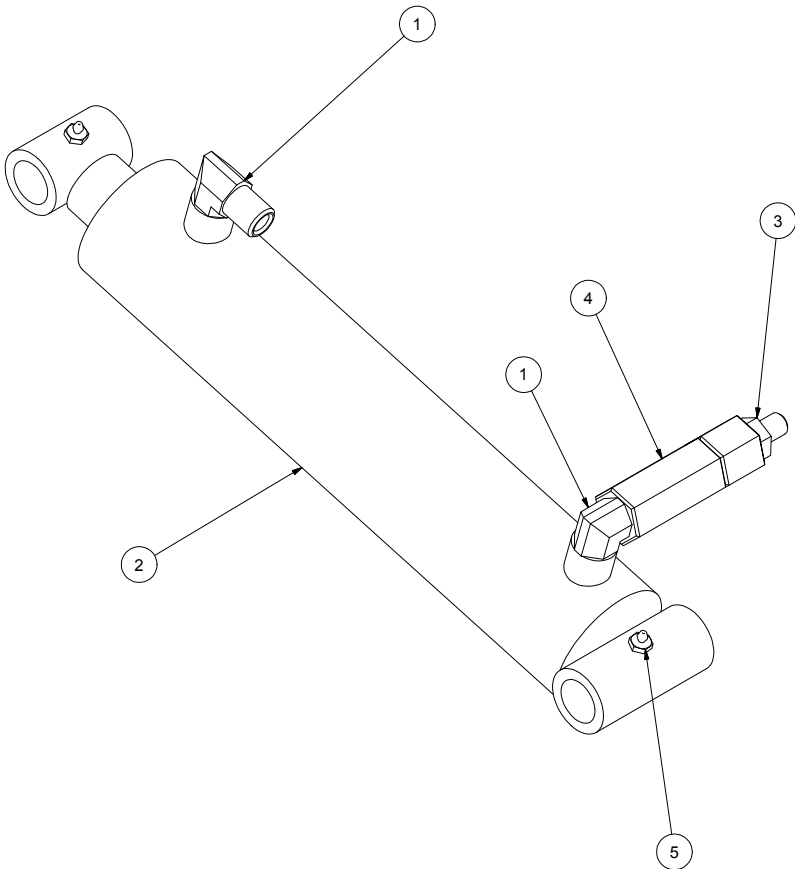

10 - ROTARY TABLE

PARTS LIST				PARTS LIST			
ITEM	QTY	PART	DESCRIPTION	ITEM	QTY	PART	DESCRIPTION
1	1	223047	ROTARY TABLE	22	2	223041	ROD
2	1	223031	COVER	23	2	500084	BOLT
3	1	322295	GREASE FITTING	24	1	223042	SHIELD
4	1	301050	SPROCKET	25	1	223044	TABLE LOCK
5	2	303050	FLANGE	26	1	223045	BRACKET
6	1	301101	SPROCKET	27	6	501022	FLANGE NUT
7	1	223032	SPACER	28	2	500444	CARRIAGE BOLT
8	1	223035	SPROCKET	29	1	223046	PLASTIC CUT HOLDER
9	2	507015	ALLEN SET SCREW	30	3	500042	BOLT
10	1	224039	KEY	31	1	502008	FLAT WASHER
11	1	223036	SHAFT	32	1	303000	BEARING
12	4	507003	ALLEN SET SCREW	33	4	322603	STRAP
13	6	501031	NYLON NUT	34	2	500442	CARRIAGE BOLT
14	1	224035	KEY	35	1	210758	SUPPORT MONTAGE
15	1	500248	BOLT	36	2	501030	NYLON NUT
16	9	501035	NYLON NUT	37	2	500004	BOLT
17	4	303024	BEARING	38	1	325145	SECURITY TRIANGLE
18	8	500246	BOLT	39	2	501032	NYLON NUT
19	1	223039	DRIVING ROLLER	40	2	500440	CARRIAGE BOLT
20	1	223040	TRACTED ROLLER	41	1	222055	SUPPORT
21	2	223049	SUPPORT ROLLER				

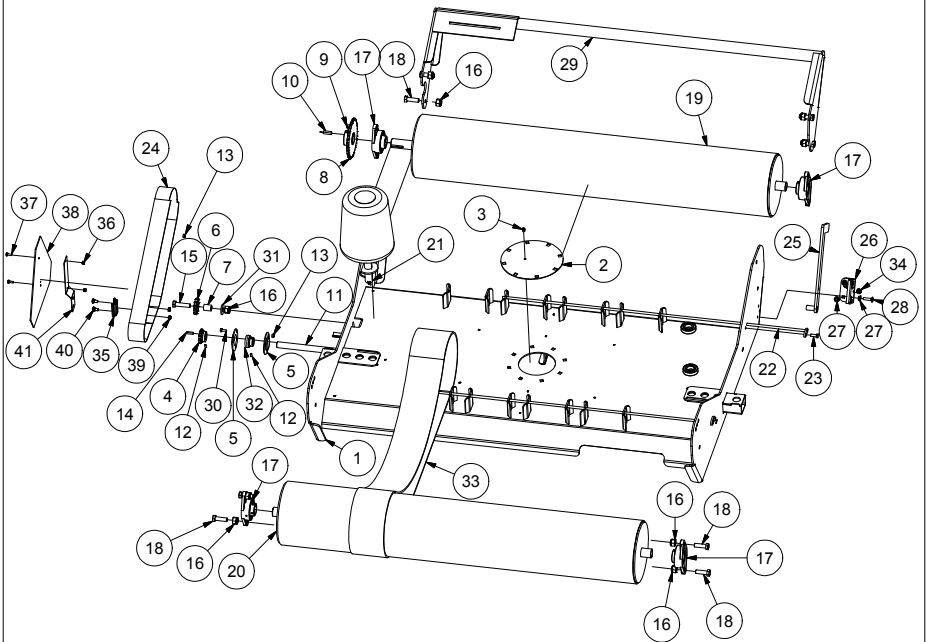

11 - PLASTIC CUT AND HOLD

PARTS LIST				PARTS LIST			
ITEM	QTY	PART	DESCRIPTION	ITEM	QTY	PART	DESCRIPTION
1	1	224051	FRAME	20	1	224056	SHIELD
2	1	224052	BLADE HOLDER	21	1	224057	ARM
3	2	320013	SPRING PIN	22	1	224058	BUMPER SHIELD
4	1	224112	SPRING BINDER	23	1	224059	SLIDER GUIDE
5	1	501002	NUT	24	10	502002	FLAT WASHER
6	1	304003	SPRING	25	1	224113	BUMPER ARM
7	1	218006	WASHER	26	1	224114	SPACER
8	3	218025	WASHER	27	1	500570	SHOULDER SCREW
9	1	320002	COTTER PIN	28	1	224061	SLIDER
10	4	322299	GREASE FITTING	29	1	224062	BUMPER
11	1	224004	HOSE HOLDER	30	1	501034	NYLON NUT
12	1	500444	CARRIAGE BOLT	31	1	500177	BOLT
13	1	325202	BLADE	32	1	304006	SPRING
14	3	500001	BOLT	33	2	450541	HYDRAULIC FITTING
15	4	500442	CARRIAGE BOLT	34	1	467000	HYDRAULIC CYLINDER
16	5	501022	FLANGE NUT	35	2	320044	COTTER PIN
17	1	224054	SIDE PLATE	36	1	501032	NYLON NUT
18	11	500004	BOLT	37	12	502044	LOCK WASHER
19	1	224055	SIDE PLATE				

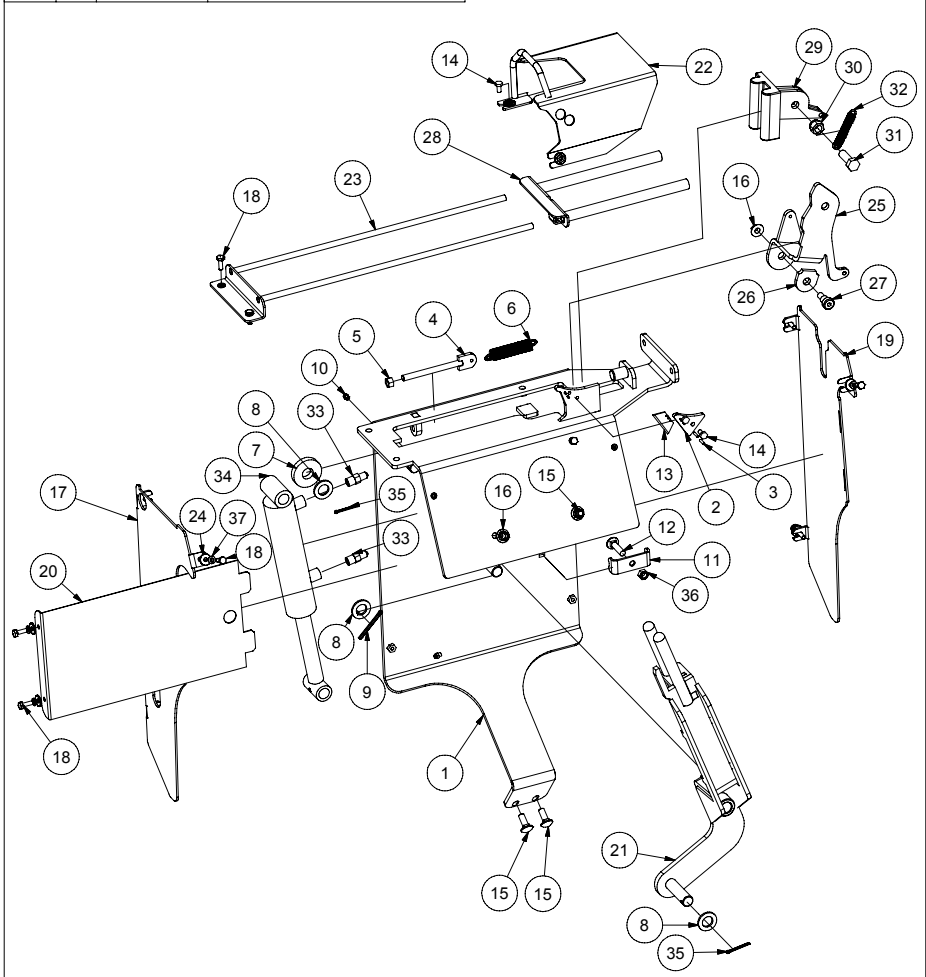

12 - CENTRAL HUB

PARTS LIST			
ITEM	QTY	PART	DESCRIPTION
1	1	303996	BEARING
2	1	303997	BEARING
3	1	303992	BEARING
4	1	303993	BEARING
5	1	303004	DUST CAP
6	1	485552	SWIVEL HUB
7	1	300511M3	MITTER GEAR
8	4	507005	ALLEN SET SCREW
9	2	451211	HYDRAULIC FITTING
10	1	224190	HUB
11	1	224014	KEY
12	1	223021	SHIELD
13	1	223023	SHIELD
14	1	223024	SHIELD
15	1	223025	LOCK
16	3	303005	O-RING
17	1	223022-2	GEAR
18	8	501034	NYLON NUT
19	6	500004	BOLT
20	1	223020	WASHER
21	1	300509	MITTER GEAR
22	1	224189	WASHER
23	1	501076	CASTLE NUT
24	1	206802	KEY
25	1	320020	COTTER PIN
26	1	303989	BEARING
27	18	500175-1	BOLT
28	18	501044-1	STOVER LOCK NUT
29	8	500179	BOLT

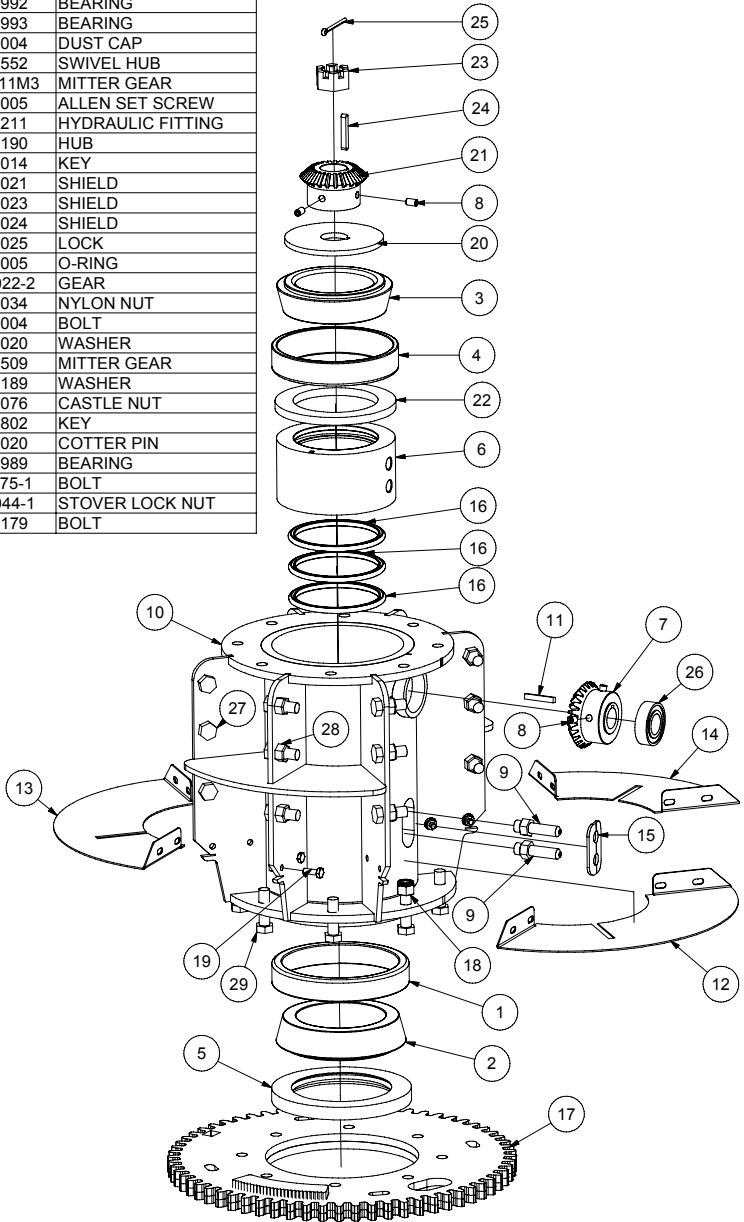

13 - LOADING ARM

PARTS LIST			
ITEM	QTY	PART	DESCRIPTION
1	1	223058	LOCK PIN
2	1	304010	SPRING
3	1	322299	GREASE FITTING
4	1	223059	OUTER FORK
5	2	502004	FLAT WASHER
6	4	500088	BOLT
7	4	501032	NYLON NUT
8	2	322299	GREASE FITTING
9	1	223087-1	CAM
10	1	223055	LOCK
11	1	223056	BALE STOPPER
12	3	500501	CARRIAGE BOLT
13	3	501024	FLANGE NUT
14	1	223057-1	LOADING ARM FRAME
15	1	303051	BUSHING

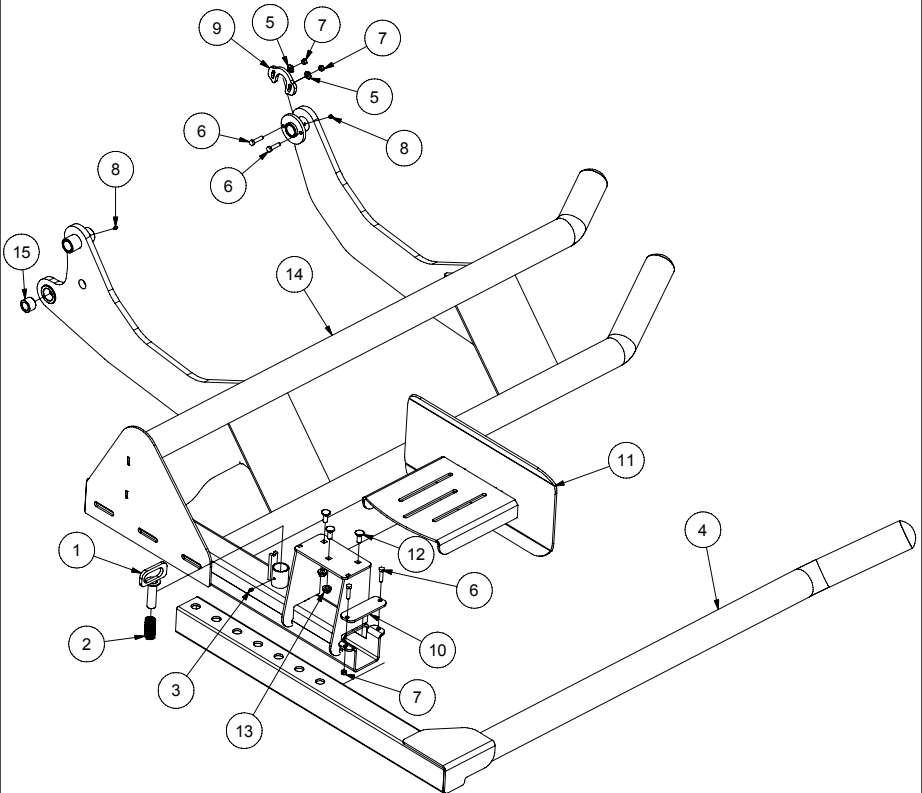

13 - LOADING ARM

PARTS LIST			
ITEM	QTY	PART	DESCRIPTION
1	1	450712	HYDRAULIC FITTING
2	1	467152	HYDRAULIC CYLINDER
3	2	322299	GREASE FITTING
4	2	223098	CYLINDER AXLE
5	2	320005-1	SNAP RING
6	2	223099	WASHER
7	1	450712M	HYDRAULIC FITTING

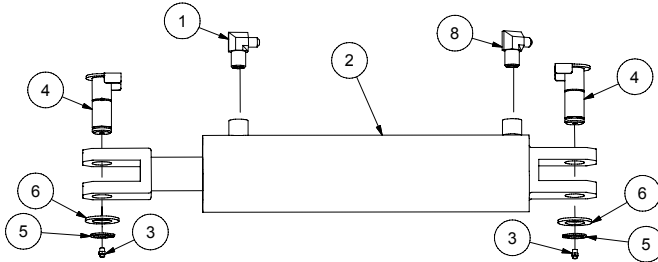

PARTS LIST			
ITEM	QTY	PART	DESCRIPTION
1	2	501024	FLANGE NUT
2	2	500501	CARRIAGE BOLT
3	2	500173	BOLT
4	2	502048	LOCK WASHER
5	1	223083	COUNTERWEIGHT
6	1	223082	SUPPORT

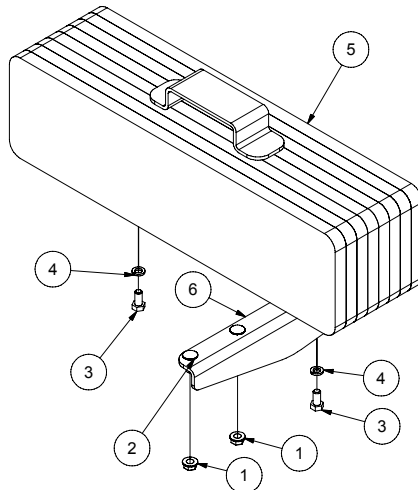

13 - LOADING ARM

PARTS LIST			
ITEM	QTY	PART	DESCRIPTION
1	1	223060	REAR ATTACHMENT
2	1	501024	FLANGE NUT
4	2	500501	CARRIAGE BOLT
5	1	223061	PIN
6	1	320010	LOCK
7	7	501024	FLANGE NUT
8	1	501032	NYLON NUT
9	1	500096	BOLT
15	5	500504	CARRIAGE BOLT

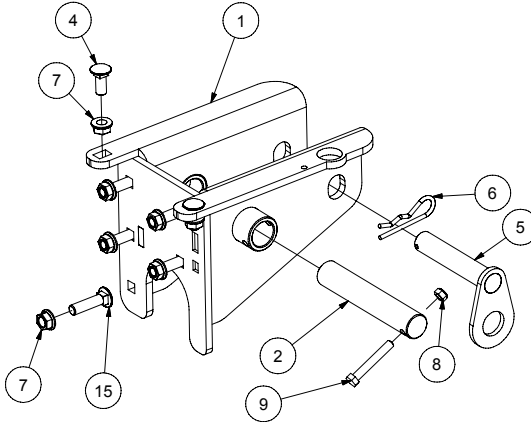

PARTS LIST			
ITEM	QTY	PART	DESCRIPTION
1	1	223063	FRONT ATTACHMENT
2	1	223066	PIN
3	6	500502	CARRIAGE BOLT
4	1	502004	FLAT WASHER
5	1	223065	LEVER
6	1	223064	SPACER
7	6	501024	FLANGE NUT
8	1	500096	BOLT
9	3	501032	NYLON NUT
10	2	500088	BOLT

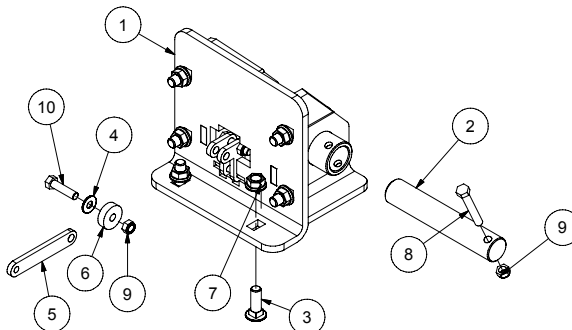

14 - STABILIZER

PARTS LIST			
ITEM	QTY	PART	DESCRIPTION
1	5	500334	BOLT
2	2	223170	REAR STABILIZER
3	1	500333	BOLT
4	7	501057	HALF NYLON NUT
5	4	322299	GREASE FITTING
6	2	223171	FRONT STABILIZER
7	1	223172	REAR STABILIZER SUPPORT
8	14	501024	FLANGE NUT
9	14	500500	CARRIAGE BOLT
10	2	467026	CYLINDER
11	1	500330	BOLT
12	4	450712	HYDRAULIC FITTING
13	4	322295	GREASE FITTING
14	2	223173-1	STABILIZER SUPPORT
15	1	223304	ATTACHMENT
16	1	320043	COTTER PIN

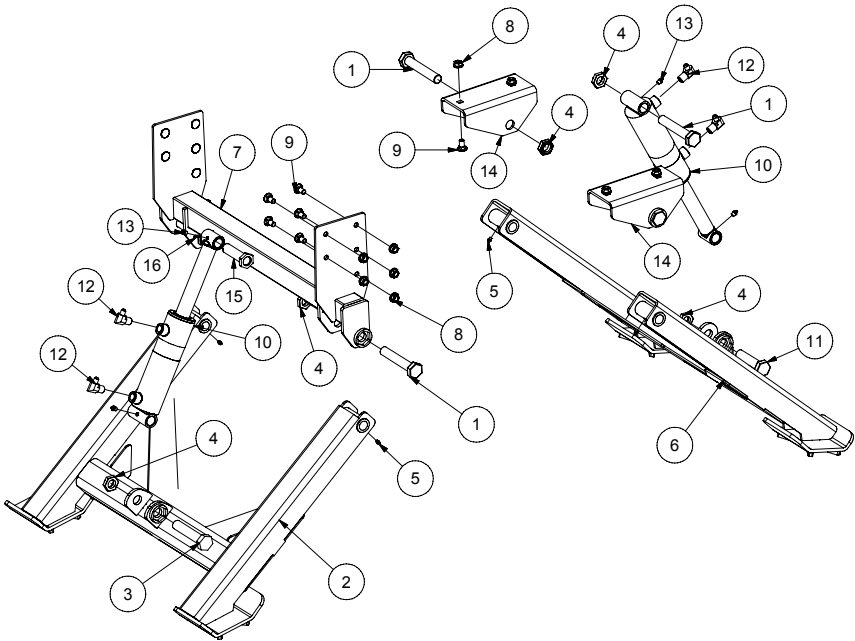



ANDERSON

15 - DROP OFF

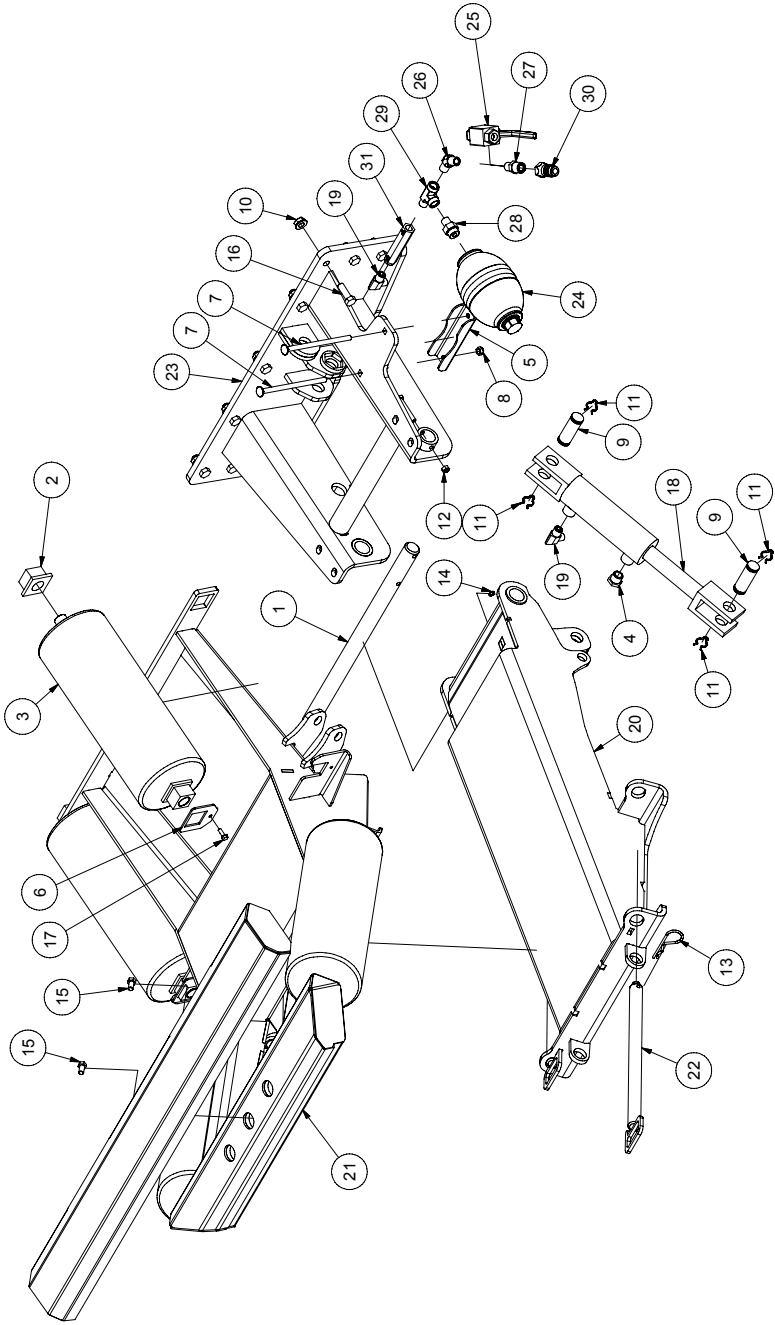

PARTS LIST		
ITEM	QTY	PART DESCRIPTION
1	1	223094 DROP OFF AXLE
2	8	224092 BUSHING
3	4	210523 ROLLER
4	1	470993 HYDRAULIC FITTING
5	1	223008 SUPPORT
6	4	210521 ROLLER LOCK
7	2	500455 CARRIAGE BOLT
8	2	501032 NYLON NUT
9	2	467500 CYLINDER PIN
10	17	501024 FLANGE NUT
11	4	467501 CYLINDER CLIP PIN
12	1	501031 NYLON NUT
13	4	320039 HITCH PIN
14	4	322299 GREASE FITTING
15	2	500082 BOLT
16	9	500177 BOLT
17	4	507039-1 SELF-DRILLING SCREW
18	1	467098 HYDRAULIC CYLINDER
19	2	450711 HYDRAULIC FITTING
20	1	223089-1 DROP OFF PLATE
21	1	223090-1 TABLE
22	2	223091-1 TABLE AXLE
23	1	223088-1 DROP OFF ATTACHMENT
24	1	470108 ACCUMULATOR
25	1	466999-1 HYDRAULIC VALVE
26	1	450132 HYDRAULIC FITTING
27	1	450007 HYDRAULIC FITTING
28	1	451094 HYDRAULIC FITTING
29	1	450262 HYDRAULIC FITTING
30	1	452000 HYDRAULIC FITTING
31	1	465051 DOUBLE RELIEF VALVE

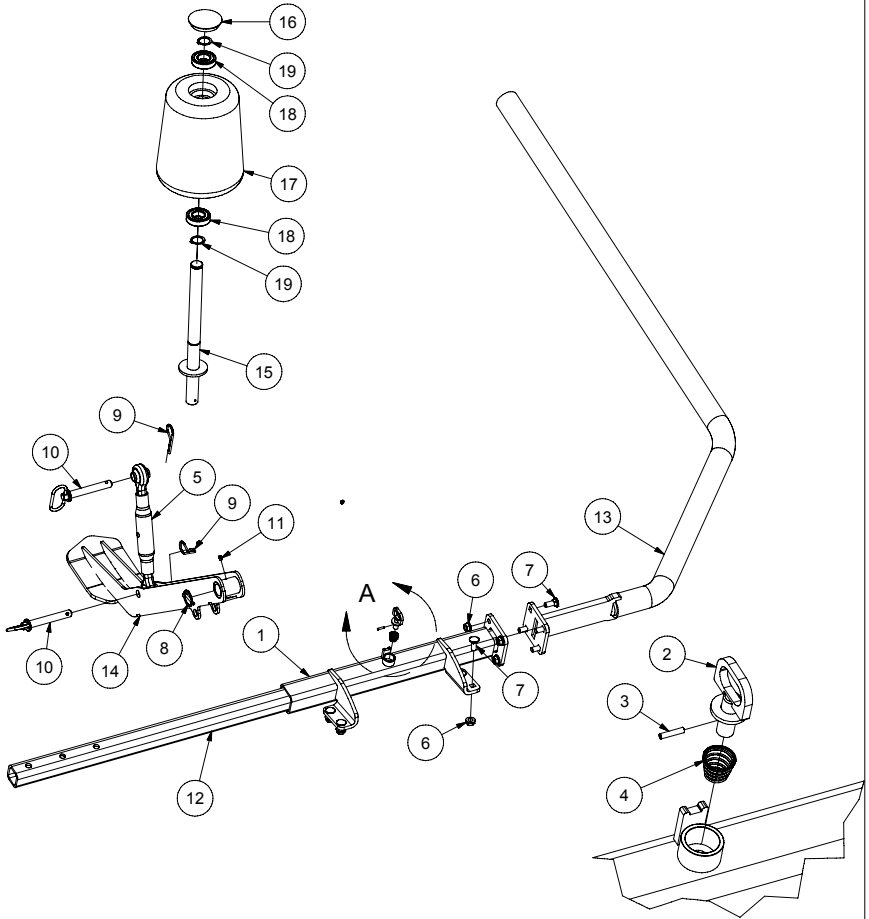

DETAIL A

PARTS LIST			
ITEM	QTY	PART	DESCRIPTION
1	1	223093	ARM SUPPORT
2	1	223185	ARM LOCK
3	1	320073	SPRING PIN
4	1	304034	SPRING
5	1	224175	TOP LINK
6	17	501024	FLANGE NUT
7	8	500501	CARRIAGE BOLT
8	1	320007	LINCHPIN
9	4	320039	HITCH PIN
10	2	320082	TOP LINK PIN
11	4	322299	GREASE FITTING
12	1	223183	FIXED PART OF ARM
13	1	223184	REMOVABLE PART OF ARM
14	2	223186-1	OUTRIGGER
15	1	223187	ROLLER SUPPORT AXLE
16	1	325107	CAP
17	1	325112	ROLLER SUPPORT
18	2	303045	BEARING
19	2	320006	RETAINING RING



ANDERSON

16 - DIAGRAMME HYDRAULIQUE 680 / 680 D 680 / 680 D HYDRAULIC DIAGRAM

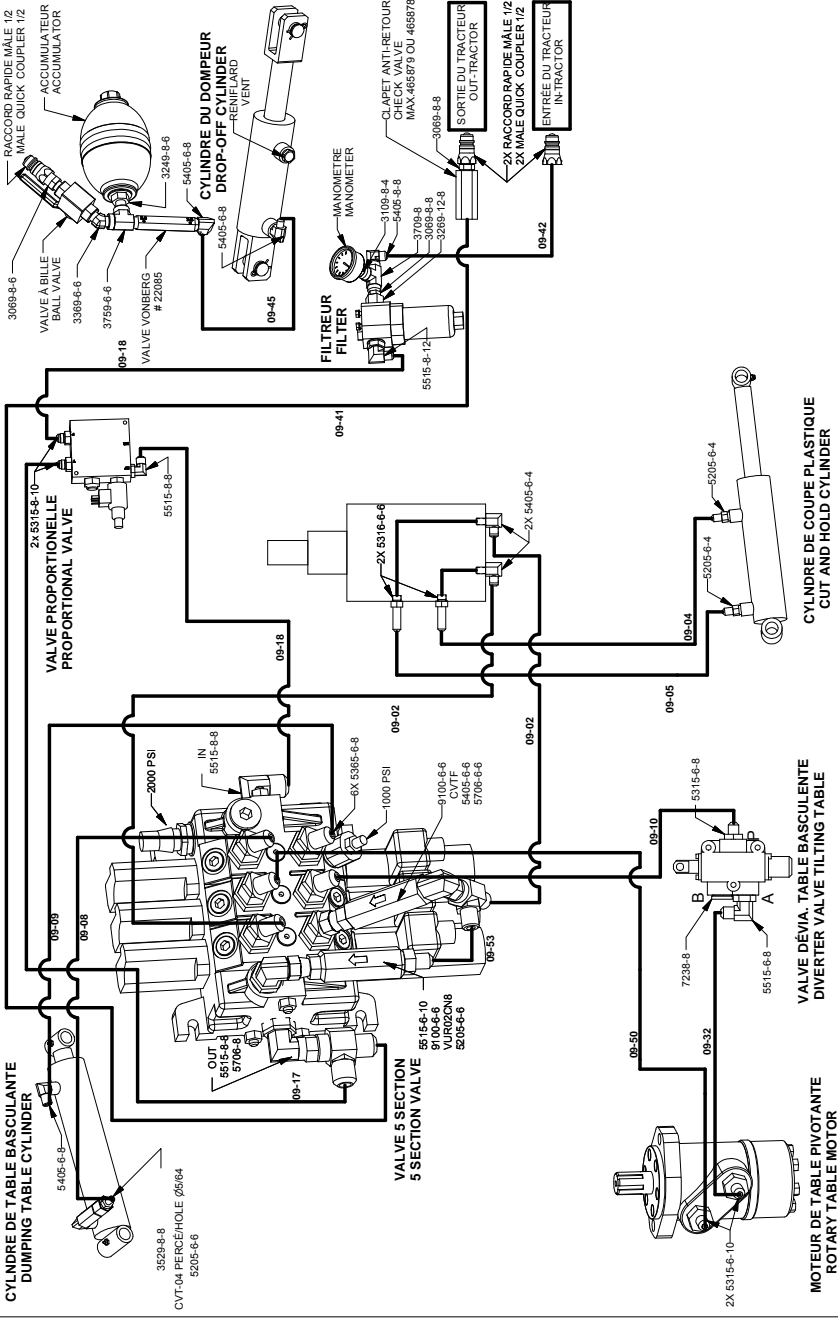



16 - DIAGRAMME HYDRAULIQUE 680 L / 680 LD
680 L / 680 LD HYDRAULIC DIAGRAM

ANDERSON

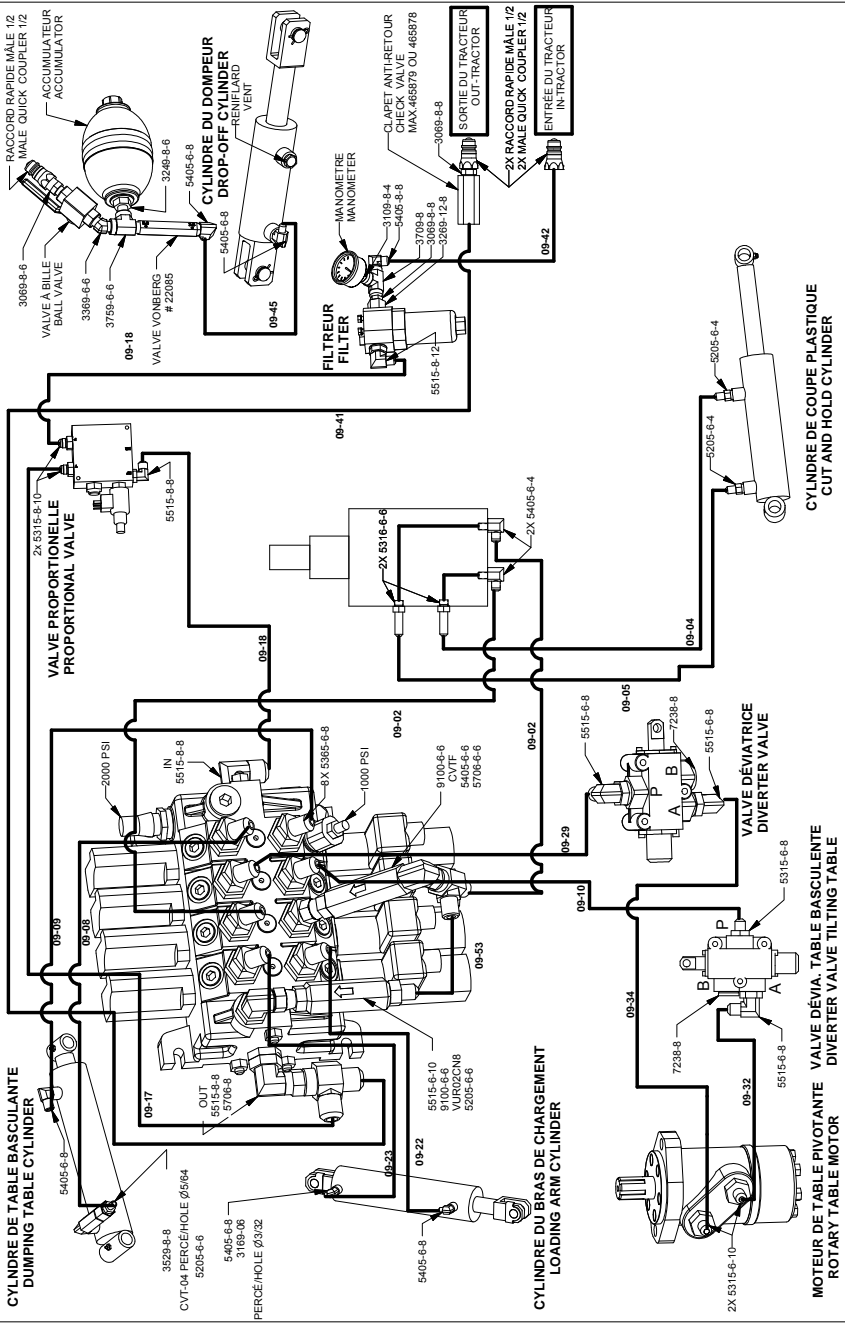



16 - DIAGRAMME HYDRAULIQUE 680 / 680 D AVEC PATTES 680 / 680 D WITH OUTRIGGERS HYDRAULIC DIAGRAM

ANDERSON

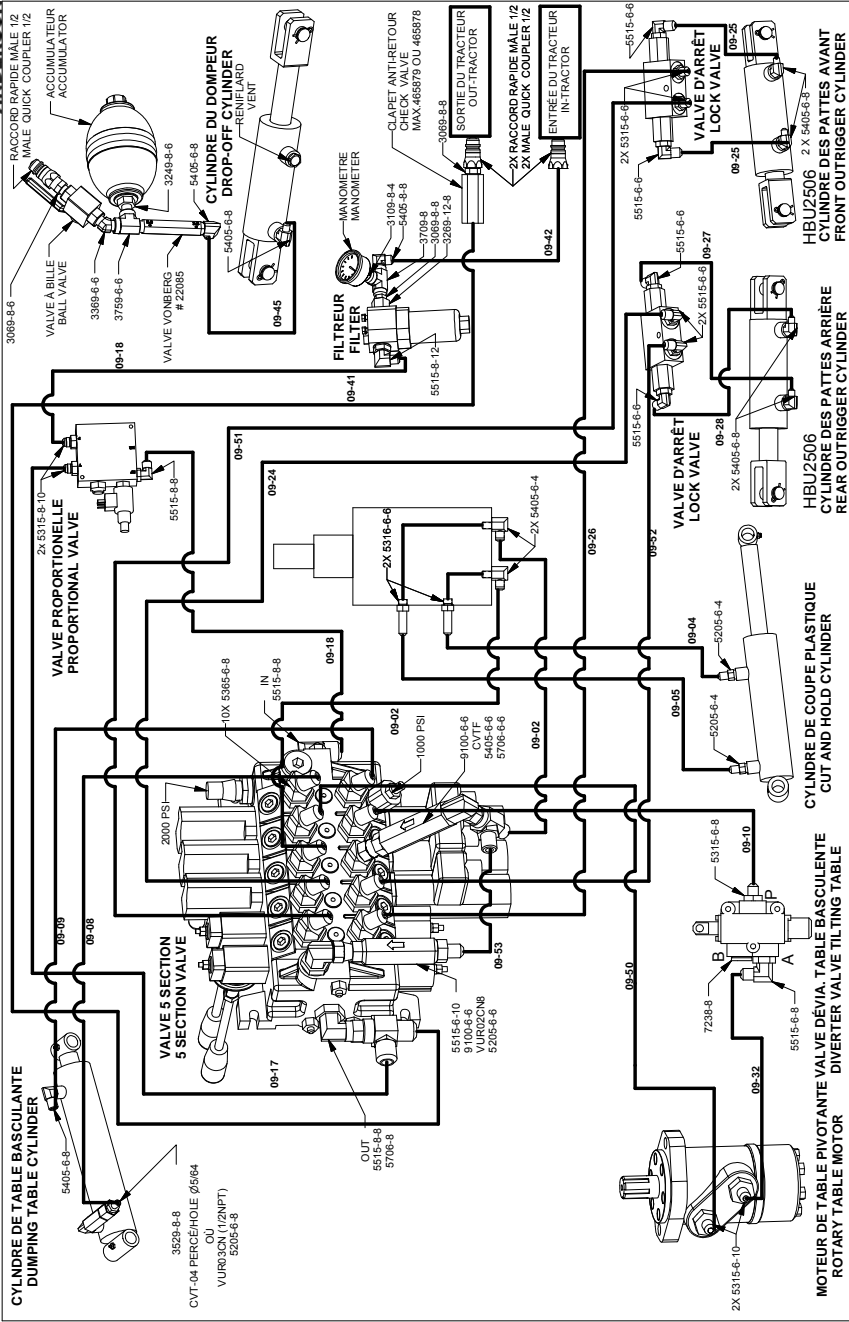



ANDERSON

**16 - DIAGRAMME HYDRAULIQUE 680 L / 680 LD AVEC UNITÉ DE PUISSANCE
680 L / 680LD WITH POWER UNIT HYDRAULIC DIAGRAM**

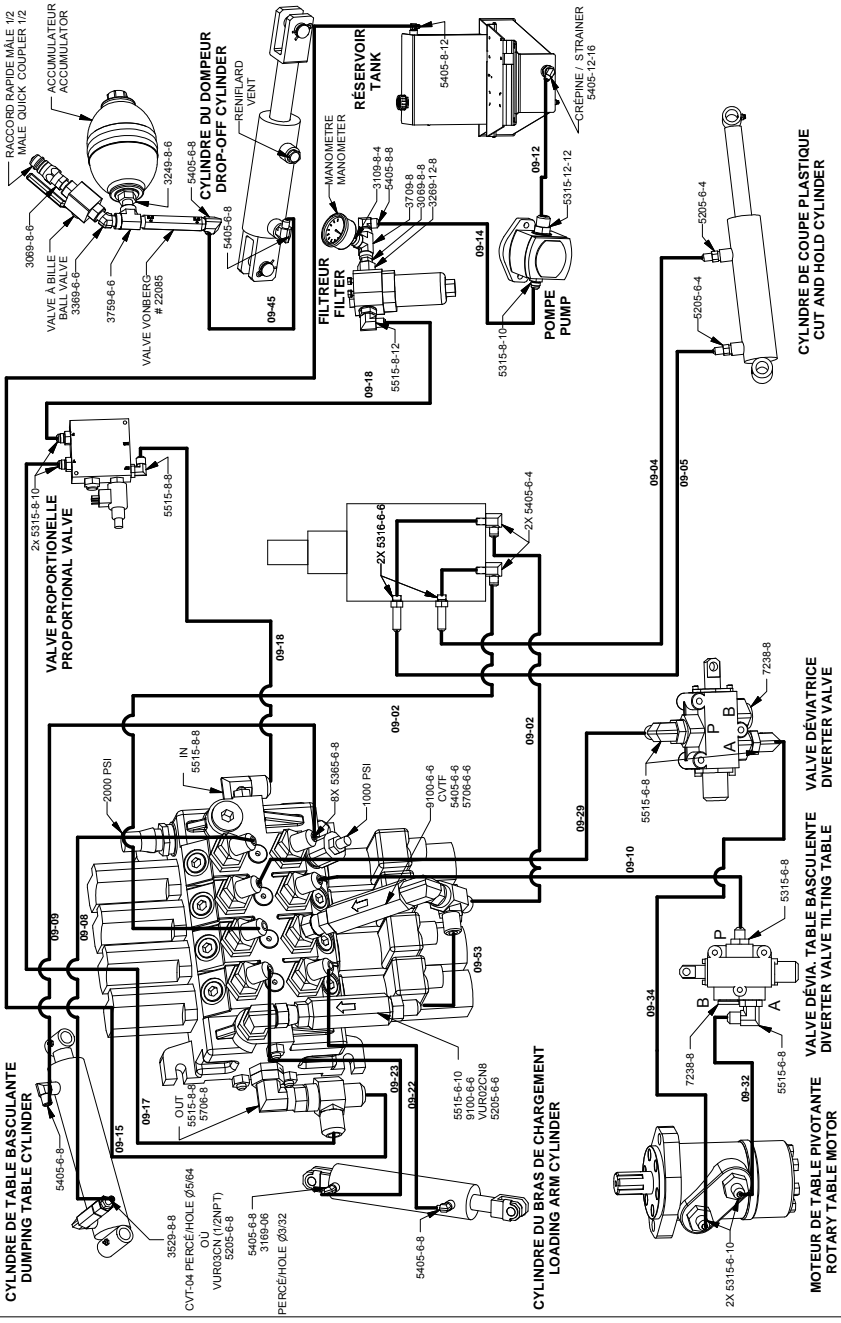

Groupes Anderson / Anderson Group, 5125 de la Plaisance Chesterville (Québec) G0P 1J0 Email : service@anderson-equipment.com

16 - DIAGRAMME HYDRAULIQUE 680 / 680 D CIRCUIT FERMÉ
CLOSE CENTER 680 / 680 D HYDRAULIC DIAGRAM

ANDERSON

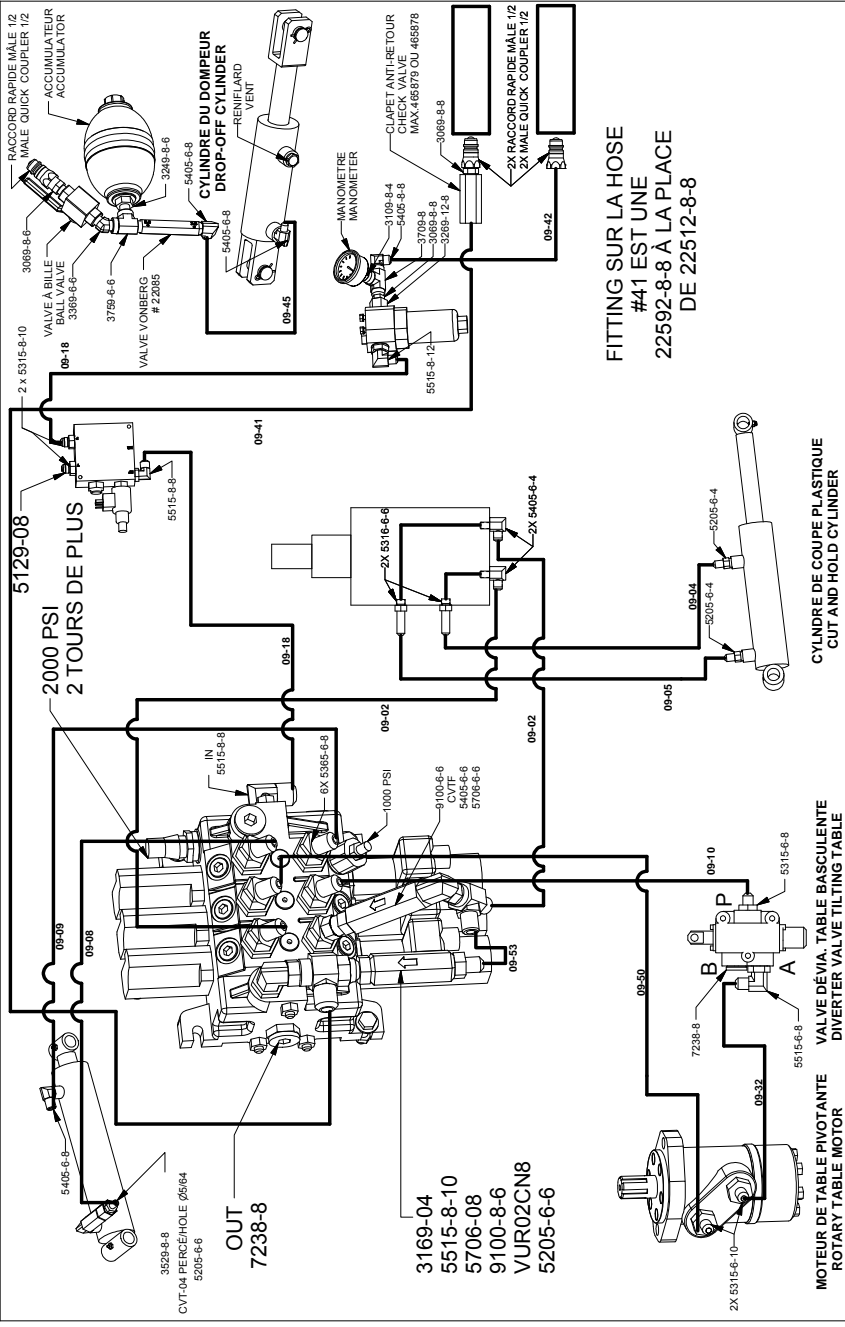



16 - LISTE DE BOYAUX / HOSE LIST

LISTE DE BOYAUX / HOSE LIST			
DESCRIPTION	NUMÉRO / NUMBER	DESCRIPTION	NUMÉRO / NUMBER
09-01	223101	09-25	223125
09-02	223150	09-26	223164
09-04	223152	09-27	223176-1
09-05	223153	09-28	223177-1
09-06	223106	09-29	223129
09-07	223107	09-30	223130
09-08	223154	09-31	223131
09-09	223155	09-32	223132
09-10	223156-1	09-33	223133
09-12	223158-1	09-34	223134
09-13	223113	09-37	223137
09-14	223159	09-40	223140
09-15	223115	09-41	223163
09-16	223116	09-42	223162
09-17	223160	09-45	223178-1
09-18	223161	09-50	223157
09-22	223122-1	09-51	223165-1
09-23	223123-1	09-52	223167-1
09-24	223166-1	09-53	223175

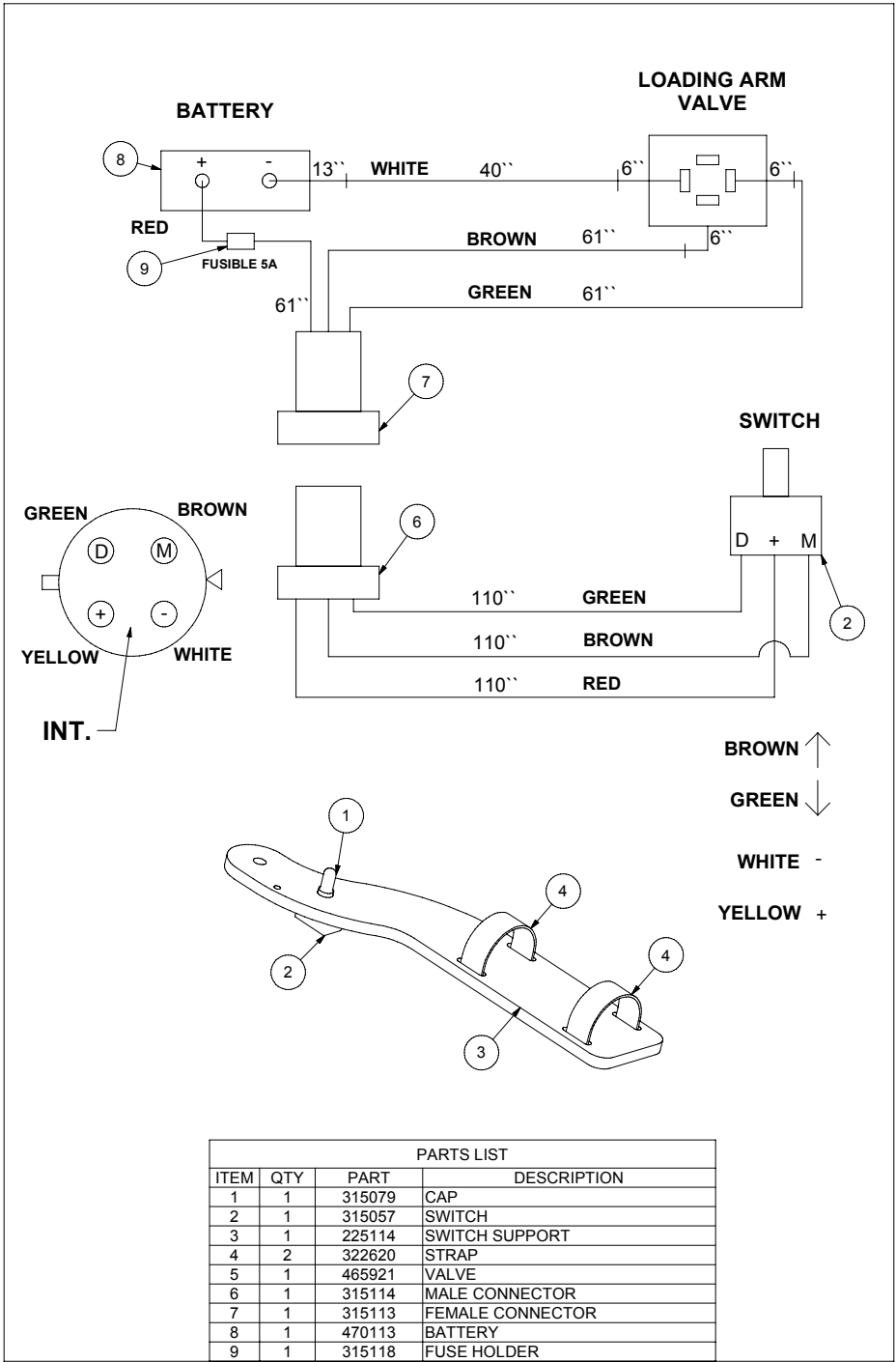
17 - LOADING ARM ELECTRIC DIAGRAM



ANDERSON

18 - DIAGRAMME ÉLECTRIQUE 680 / 680 ELECTRICAL DIAGRAM

