



## OPERATOR'S MANUAL



# Pallet Fork Add-A-Grapple

PRECISION MANUFACTURING, INC.

424 N. Harding Avenue  
Sedalia, MO 65301  
Phone (660) 827 6131  
Fax (660) 827-7366  
[www.precisionmfg.com](http://www.precisionmfg.com)

MANUAL #PG042012

## TABLE OF CONTENTS

<b>INTRODUCTION.....</b>	<b>3</b>
<b>REGISTRATION.....</b>	<b>3</b>
<b>WARRANTY.....</b>	<b>3</b>
<b>SAFETY AND SIGNAL WORDS.....</b>	<b>4</b>
<b>EQUIPMENT SAFETY GUIDELINES.....</b>	<b>5</b>
<b>SAFETY SIGN LOCATIONS.....</b>	<b>6</b>
<b>SAFETY DECAL CARE.....</b>	<b>7</b>
<b>SAFETY BEFORE OPERATION.....</b>	<b>8</b>
<b>SAFETY DURING OPERATION.....</b>	<b>9-10</b>
<b>SAFETY FOLLOWING OPERATION.....</b>	<b>10</b>
<b>SAFETY IN HIGHWAY AND TRANSPORT OPERATION.....</b>	<b>11</b>
<b>SAFETY WHILE PERFORMING MAINTENANCE.....</b>	<b>12-13</b>
<b>BOLT TORQUE.....</b>	<b>14</b>
<b>PARTS LIST.....</b>	<b>15</b>
<b>INSTALLATION INSTRUCTIONS .....</b>	<b>16</b>
<b>OPERATING INSTRUCTIONS.....</b>	<b>17</b>
<b>MAINTENANCE INSTRUCTIONS.....</b>	<b>17</b>

## INTRODUCTION

Thank you for purchasing your new **Pallet Fork Add-A-Grapple**, also known as the **Pallet Grapple** by Precision Manufacturing. The **Pallet Grapple** is designed to be mounted on an existing hydraulic loader with a fork or tine attachment. The tines must be no larger than 4" by 1 3/4" thick. The **Pallet Grapple** is designed to **hold brush, limbs, logs, boulders, and pipes or stabilize loads on a pallet**. No other use is intended.

Please read and understand this manual before operating this equipment.

## REGISTRATION

Registration card must be completed and mailed prior to use of equipment. We respect your privacy. Your personal information will not be shared without permission. If your registration card is lost or misplaced, please contact Precision Manufacturing for a replacement.

## WARRANTY

Precision Manufacturing warrants all new products manufactured and/or marketed by Precision Manufacturing to be free from defects in material and workmanship under normal usage and service for one year from the date of first use by the buyer, or for one year from the date of the purchase as indicated on the receipt/invoice, whichever occurs first. Repairs or replacements covered under this warranty shall be warranted for the remaining portion of the original warranty period or ninety (90) days, whichever is longer. This warranty shall apply provided the products are returned to Precision Manufacturing's designated facility freight prepaid.

This Warranty excludes all products or component parts that, in the opinion of Precision Manufacturing, have been subjected to negligent use, misuse, alteration, or accident, or that have been repaired with component parts other than those manufactured or used by Precision Manufacturing.

Precision Manufacturing does not warrant component parts supplied by manufacturers who provide separate warranties for their merchandise. It is the obligation of the buyer to contact these suppliers directly for warranty claims, service, and replacement of defective materials and component parts.

Precision Manufacturing reserves the right to make design changes, improve design, or change specifications at any time without any contingent obligation to owners of products previously sold by Precision Manufacturing.

This Warranty shall not be interpreted to render Precision Manufacturing liable for injuries or damages of any kind, direct, consequential, or contingent, to persons or property. Precision Manufacturing shall not be liable for any recovery greater than the cost of repair of defects in workmanship.

Precision Manufacturing shall not be held responsible by buyers for failure to perform any of the obligations of this Warranty if such failures are the result of circumstances of Force Majeure, such as, but not limited to floods, earthquakes, transportation strikes, labor disputes with outside suppliers, or any other conditions beyond the control of Precision Manufacturing.

Warranty service is available by contacting your dealer or distributor.

This Warranty gives you specific legal rights and you may have other rights.

## SAFETY

**TAKE NOTE! THIS SAFETY ALERT SYMBOL FOUND THROUGHOUT THIS MANUAL IS USED TO CALL YOUR ATTENTION TO INSTRUCTIONS INVOLVING YOUR PERSONAL SAFETY AND THE SAFETY OF OTHERS. FAILURE TO FOLLOW THESE INSTRUCTIONS CAN RESULT IN INJURY OR DEATH.**



*THIS SYMBOL MEANS*

**ATTENTION!**

**BECOME ALERT!**

**YOUR SAFETY IS INVOLVED!**

### SIGNAL WORDS

**Note the use of the signal words DANGER, WARNING and CAUTION with the safety messages. The appropriate signal word for each has been selected using the following guidelines:**

**DANGER:** Indicates an imminently hazardous situation that, if not avoided, will result in death or serious injury. This signal word is to be limited to the most extreme situations typically for machine components, which, for functional purposes, cannot be guarded.

**WARNING:** Indicates a potentially hazardous situation that, if not avoided, could result in death or serious injury, and includes hazards that are exposed when guards are removed. It may also be used to alert against unsafe practices.

**CAUTION:** Indicates a potentially hazardous situation that, if not avoided may result in minor or moderate injury. It may also be used to alert against unsafe practices.

If you have questions not answered in this manual or require additional copies or the manual is damaged, please contact your dealer or Precision Manufacturing, Inc., 424 North Harding Ave. Sedalia, MO 65301. Phone (660) 827-6131, Fax (660) 827-7366.



## SAFETY – YOU CAN LIVE WITH IT

### EQUIPMENT SAFETY GUIDELINES

Safety of the operator is one of the main concerns in designing a new piece of equipment. Designers and manufacturers build in as many safety features as possible. However, every year many accidents occur which could have been avoided by a few seconds of thought and a more careful approach to handling equipment. You, the operator, can avoid personal injury. Study the following precautions and insist those working with you, or for you, follow them.

In order to provide a better view, certain photographs or illustrations in this manual may show an assembly with a safety shield removed. However, equipment should never be operated in this condition. Keep all shields in place. If shield removal becomes necessary for repairs, replace the shield prior to use.

Replace any CAUTION, WARNING, DANGER or instruction safety decal that is not readable or is missing. Location of such decals is indicated in this manual.

Do not attempt to operate this equipment under the influence of drugs or alcohol.

Review the safety instructions with all users annually.

This equipment is dangerous to children and persons unfamiliar with its operation. The operator should be a responsible adult familiar with machinery and trained in this equipment's operations. Do not allow persons to operate or assemble this unit until they have read this manual and have developed a thorough understanding of the safety precautions and of how it works.

To prevent injury or death, use a tractor or skid-steer equipped with a Roll-Over Protective System (ROPS)/ (FOPS). Do not paint over, remove or deface any safety signs or warning decals on your equipment. Observe all safety signs and practice the instructions on them.

Never exceed the limits of a piece of machinery. If its ability to do a job, or to do so safely, is in questions, **DON'T TRY IT.**



## SAFETY SIGN LOCATIONS

The types of Safety Signs on the equipment are shown in the illustration below. Good safety requires that you familiarize yourself with the various Safety Signs, the type of warning and the area, or particular function related to that area, that requires your **SAFETY AWARENESS**.

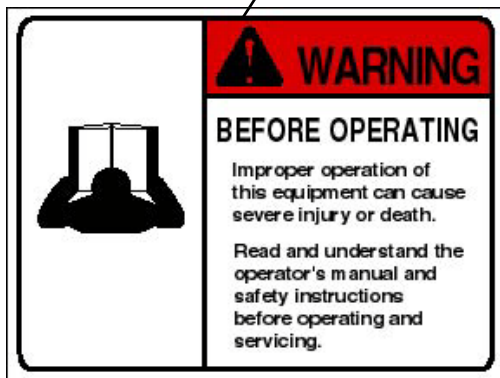

## SAFETY DECAL CARE



- . Keep safety decals and signs clean and legible at all times.
- . Replace safety decals and signs that are missing or have become illegible.
- . Replaced parts that displayed a safety sign should also display the current sign.
- . Safety decals or signs are available from your Distributor, Dealer Parts Department, or the Manufacturer.

### **How to install Safety Decals**

- . Be sure that the installation area is clean and dry.
- . Decide on the exact position before you remove the backing paper.
- . Remove the smallest portion of the split backing paper.
- . Align the decal over the specified area and carefully press the small portion with the exposed sticky backing in place.
- . Slowly peel back the remaining paper and carefully smooth the remaining portion of the decal in place.
- . Small air pockets can be pierced with a pin and smoothed out using the piece of decal backing paper.



**REMEMBER: Your best assurance against accidents is a careful and responsible operator. If there is any portion of this manual or function you do not understand, contact the local authorized dealer or the manufacturer.**



## **BEFORE OPERATION**

- . Carefully study and understand this manual before operating attachment.
- . Do not wear loose-fitting clothing, which may catch in moving parts.
- . Always wear protective clothing and substantial shoes.
- . It is recommended that suitable protective hearing and sight protectors (eye protection) are worn.
- . Keep bolts tightened to specified torque.
- . Assure that all tires are inflated evenly.
- . Give the unit a visual inspection for any loose bolts, worn parts or cracked welds, and make the necessary repairs. Follow the maintenance safety instructions included in this manual.
- . Be sure that there are no tools lying on or in the equipment.
- . Do not use the unit until you are sure that the area is clear, especially children and animals.
- . Because it is possible that this equipment may be used in dry areas or in the presence of combustibles, special precautions should be taken to prevent fires and fire-fighting equipment should be readily available.
- . Don't hurry the learning process or take the unit for granted. Ease into it and become familiar with your new equipment.
- . Practice operation of your equipment and its attachments. Completely familiarize yourself with your new equipment.
- . Use a tractor equipped with a Roll Over Protective System (ROPS) or (FOPS).
- . The manufacturer does not recommend usage of tractor with ROPS removed.
- . Move tractor wheels/tracks to the widest recommended settings to increase stability.





## DURING OPERATION

- . Beware of bystanders, **particularly children!** Always look around to make sure that it is safe to start the engine or move the unit. This is particularly important with higher noise levels and quiet cabs, as you may not hear people shouting.
- . **NO PASSENGERS ALLOWED** – Do not carry passengers anywhere on, or in the tractor or equipment except as required for operation.
- . Keep hands and clothing clear of moving parts.
- . Do not clean, lubricate or adjust your equipment while it is moving.
- . When halting operation, even periodically, set the tractor brakes, shut off the engine and **remove the ignition key.**
  - **DO NOT** operate near the edge of drop-offs or banks.
  - **DO NOT** operate on steep slopes as overturn may result.
  - Operate up and down (not across) intermediate slopes. Avoid sudden Starts and stops.
- . Pick the most level possible route when transporting across fields. **KEEP UNIT IN LOWERED POSITION WHEN TRANSPORTING.** Avoid the edges of ditches or gullies and steep hillsides.
- . Be extra careful when working on inclines.
- . Periodically clear the equipment of dirt, twigs or other materials to prevent Build up of dry combustible materials.
- . Maneuver the equipment at safe speeds.
- . **AVOID OVERHEAD WIRES OR OTHER OBSTACLES. CONTACT WITH OVERHEAD LINES COULD CAUSE SERIOUS INJURY OR DEATH.**
- . Avoid loose fill, rocks and holes; they can be dangerous for equipment operation or movement
- . Allow for unit length when making turns.
- . **DO NOT WALK OR WORK UNDER RAISED COMPONENTS OR ATTACHMENTS UNLESS SECURELY POSITIONED AND BLOCKED.**
- . Keep all bystanders, pets and livestock clear of the work area.
- . Operate the tractor from the operator's seat only.



### DURING OPERATION CONT.

- . Never stand alongside of unit with engine running or attempt to start engine and/or operate machine while standing alongside of unit.
- . Never leave running equipment unattended.
- . As a precaution, always recheck the equipment after each day's operation. Correct all problems. Follow the maintenance safety procedures.
- . Avoid operating the equipment on excessively steep hills and especially on hills that are steeper than 15 degrees. Avoid crossing slopes if possible and do not make sharp uphill steering corrections or a rollover could result. If your tractor starts to tip over on a slope, turn the front wheels quickly downhill to regain stability and control.

The best way to climb most hills is to drive straight up while maintaining a steady ground speed and constant engine RPM. The best way to descend most hills is straight down while using steady pressure on the brakes without locking them up. Locking the brakes in a steep downhill situation can result in loss of traction, steering and control. When you must cross a slope on soft terrain, keep the front wheels turned slightly uphill and maintain a constant speed and a straight line of travel.

Driving too fast, being inattentive and turning too sharply on slippery surfaces can result in rollovers and accidents almost quicker than any other ground condition we know of. Snow cover, wet surfaces, loose gravel and frozen ground can all contribute to this dangerous condition. In these conditions maintain a sharp focus on what you are doing and the terrain you are on. Do not make sharp turns and avoid the need for hard braking if at all possible. If you start to skid or slid in a turn, turn the front wheels in the direction of the skid to regain control.



### FOLLOWING OPERATION

- . Following operation, or when detaching, stop the tractor, set the brakes. Disengage the PTO and all power drives, shut off the engine and **remove the ignition keys**.
- . Store the unit in an area away from human activity with jaws closed.
- . Do not store equipment where it will be exposed to livestock for long periods of time. Damage and livestock injury could result.
- . Do not permit children to play on or around the stored unit.
- . Make sure all parked machines are on a hard level surface.



## **HIGHWAY AND TRANSPORT OPERATION**

- . Adopt safe driving practices.
  - Keep the brake pedals latched together at all times. NEVER USE INDEPENDENT BRAKING AS LOSS OF CONTROL AND/OR UPSET OF UNIT CAN RESULT.
  - Always drive at a safe speed relative to local conditions and ensure that your speed is low enough for an emergency stop to be safe and secure. Keep speed to a minimum.
  - Reduce speed prior to turns to avoid the risk of overturning.
  - Avoid sudden uphill turns on steep slopes.
  - Always keep the tractor in gear to provide engine braking when going down hill. Do not coast.
  - Do not drink and drive.
- . Comply with state and local laws governing highway safety and movement of farm machinery on public roads.
- . Use approved accessory lighting flags and necessary warning devices to protect operators of other vehicles on the highway during the daylight and night-time transport.
- . The use of flashing amber lights is acceptable in most localities. However, some localities prohibit their use. Local laws should be checked for all highway lighting and marking requirements.
- . When driving the tractor and equipment on the road or highway under 40 kph (20 mph) at night or during the day, use flashing amber warning lights and a slow moving vehicle (SMV) identification emblem.
- . Plan your route to avoid heavy traffic.
- . Be a safe and courteous driver. Always yield to oncoming traffic in all situations, including narrow bridges, intersections, etc.
- . Be observant of bridge loading ratings. Do not cross bridges rated lower than the gross weight at which you are operating.
- . Watch for obstructions overhead and to the side while transporting.
- . Always operate equipment in a position to provide maximum visibility at all times. Make allowances for increased length and weight of the equipment when making turns, stopping the unit, etc.



## PERFORMING MAINTENANCE

- . Good maintenance is your responsibility. Poor maintenance is an invitation for trouble.
- . Make sure there is plenty of ventilation. Never operate the engine of the tractor in a closed building. The exhaust fumes can cause asphyxiation.
- . Before working on this machine, stop the tractor, set the brakes, lower loader and attachments until solidly on the ground, disengage the PTO and all power drives, shut off engine and **remove the ignition keys**.
- . Be certain all-moving parts on attachments have come to a complete stop before attempting to perform maintenance.
- . **Always** use a safety support and block the wheels. Never use a jack to support the machine.
- . Use extreme caution when making adjustments.
- . Follow the torque chart in this manual when tightening bolts and nuts.
- . Never use your hands to locate a hydraulic leak on attachments. Use a small piece of cardboard or wood. Hydraulic fluid escaping under pressure can penetrate the skin.
- . Before disconnecting hydraulic lines, shut off hydraulic supply and relieve all hydraulic pressure.
- . Openings in the skin and minor cuts are susceptible to infection from hydraulic fluid. **If injured by escaping hydraulic fluid, see a doctor at once. Gangrene can result. Without immediate medical treatment, serious infection and reactions can occur.**



## PERFORMING MAINTENANCE CONT.

- . Replace **all shields** and guards after servicing and before moving.
- . After servicing, be sure all tools, parts and service equipment are removed.
- . Do not allow grease or oil to build up on equipment.
- . Never replace hex bolts with a grade of less than provided on the original equipment.
- . Refer to bolt torque chart for head identification marking.
- . Where replacement parts are necessary for periodic maintenance and servicing, genuine factory replacement parts must be used to restore your equipment to original specifications. The manufacturer will not claim responsibility for use of unapproved parts and/or accessories and other damages as a result of their use.
- . If equipment has been altered in any way from original design, the manufacturer does not accept any liability for injury or warranty.
- . A fire extinguisher and first aid kit should be kept readily accessible while performing maintenance on this equipment.

## BOLT TORQUE

### CHECKING BOLT TORQUE

The table shown below gives correct torque values for various bolts and cap screws. Tighten all bolts to the torques specified in chart unless otherwise noted. Check tightness of bolts periodically, using bolt torque chart as a guide. Replace with the same strength bolt.

### TORQUE SPECIFICATIONS

Bolt Diameter	Bolt Torque			
	SAE GRADE 5		SAE GRADE 8	
"A"	lb-ft	Nm	lb-ft	Nm
1/4"	8	(11)	12	(16)
3/8"	33	(45)	45	(63)
1/2"	80	(110)	115	(155)
5/8"	150	(204)	220	(299)
3/4"	290	(390)	400	(540)
1 1/4"	1,105	(1503)	1,975	(2686)

Torque figures indicated above are valid for course thread, non-greased or non-oiled threads and heads unless otherwise specified. Therefore, do not grease or oil bolts or cap screws unless otherwise specified in this manual. When using locking elements, increase torque values by 5%.

\* Torque value for bolts and cap screws are identified by their head markings.

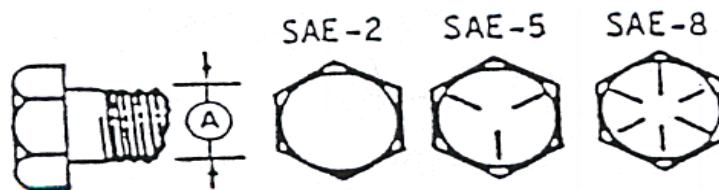

# PARTS LIST- MODEL 336 PALLET FORK ADD-A-GRAPPLE

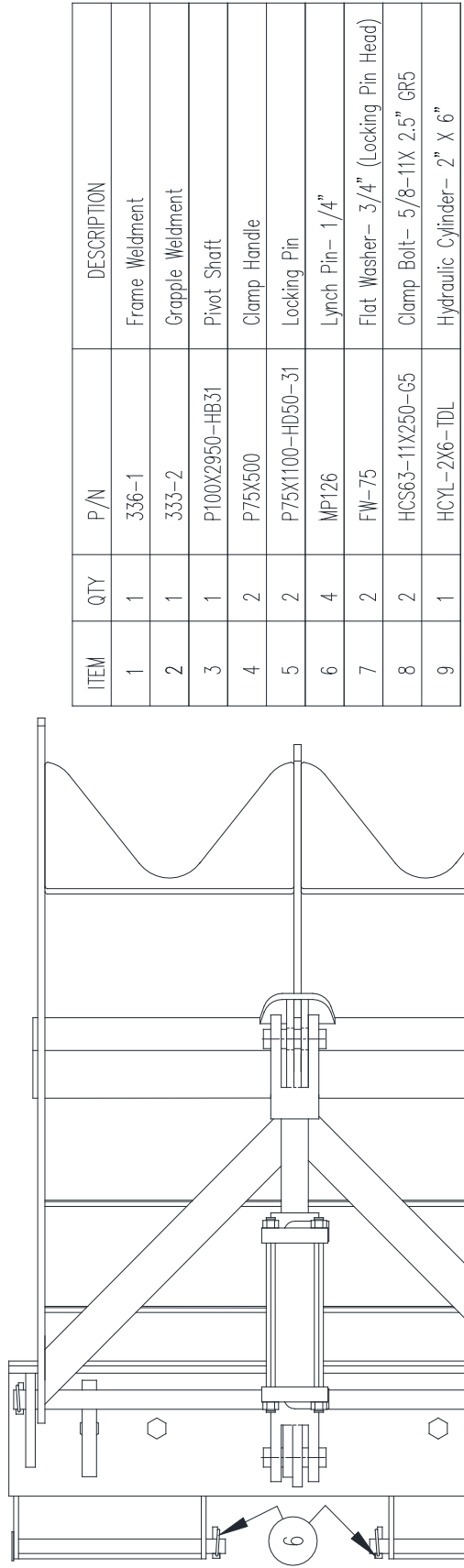

ITEM	QTY	P/N	DESCRIPTION
1	1	336-1	Frame Weldment
2	1	333-2	Grapple Weldment
3	1	P100X2950-HB31	Pivot Shaft
4	2	P75X500	Clamp Handle
5	2	P75X1100-HD50-31	Locking Pin
6	4	MP126	Lynch Pin- 1/4"
7	2	FW-75	Flat Washer- 3/4" (Locking Pin Head)
8	2	HCS63-11X250-G5	Clamp Bolt- 5/8-11X 2.5" GR5
9	1	HCYL-2X6-TDL	Hydraulic Cylinder- 2" X 6"

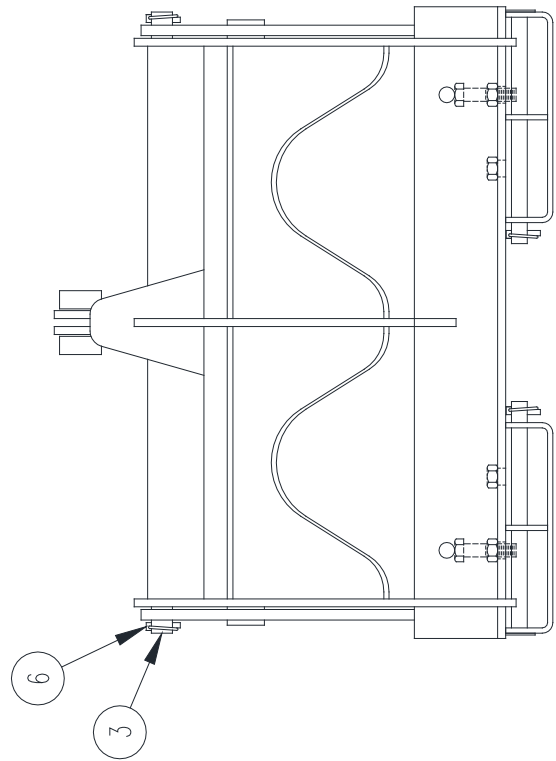

**PRECISION MFG.**  
 PALLET FORK ADD-A-GRAPPLE  
 MODEL: 336

WEIGHT= 197 LBS



# PALLET GRAPPLE

## INSTALLATION INSTRUCTIONS (Model 336)

Precision Manufacturing Pallet Grapples are designed for easy installation and simple operation.

1. Your Pallet Grapple is designed to slide onto existing pallet forks which are no wider than 4" and no more than 1 3/4" thick.
2. To install the Pallet Grapple, first remove the locking rods from the frame.
3. Adjust the distance between your forks so they will slide into either the outer or inner fork tube slots. The outer position will allow the grapple to clamp against the top of the fork. The inner position will allow the grapple to bypass the forks by about 6" to close tighter on a small load.
4. Insert the forks through a set of fork tubes until completely seated against the frame

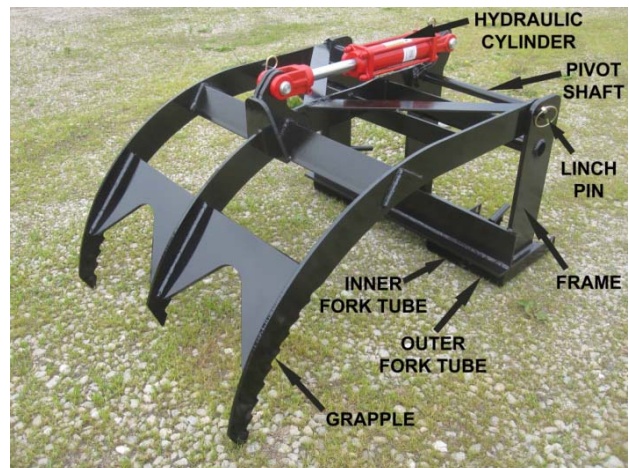

5. Insert the two locking rods through the holes in the frame. The locking rods must capture the fork against the frame so the Pallet Fork cannot be pulled off the fork while under load.

6. Lock the locking rods in place using two lynch pins.

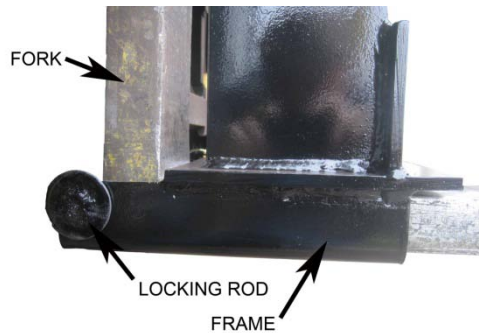

7. Screw the two clamps through the nuts over the forks and tighten them against the top of each fork to stabilize the frame while using the Pallet Grapple.

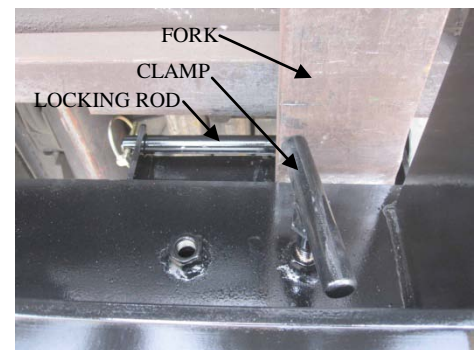

8. Attach hydraulic hoses from your hydraulic supply to the hydraulic cylinder. The cylinder ports are female 3/8" NPT threads. For best results, use a 90° fitting with swivel to help prevent twisting of hoses during movement of the grapple.



9. If you bought the optional log clamp, place the “V” of the log clamp over the ends of the grapple and fasten it in place using two 3/8” bolts, nuts and lock washers through the holes in the end plates and grapple tines. The serrated portion of the end plates should point toward the machine as opposed to away from the machine for effective use of the log clamp.



10. To remove the Pallet Grapple, simply disconnect the hydraulic hoses, loosen the clamps, remove the locking rods and back the machine out of the fork tubes.

## OPERATING INSTRUCTIONS (Model 336)

1. Observe all safety statements above while operating this piece of equipment.
2. Observe the safety labels on the Pallet Grapple unit.
3. Use your hydraulic control valve to apply pressure to the hydraulic cylinder on the Pallet Grapple. This will cause the grapple to open and close, clamping on whatever is on the forks. (CAUTION: Keep all persons and animals away from the Pallet Grapple when it is being used. Personal injury or death could occur if the grapple closes on a person or animal).
4. When the grapple is in the “open” position, it is out of the way so the forks can be used to pick up objects.
5. Clamp near the middle of a long object like a log. If there is excessive weight on one side of the unit the twisting action could cause damage to the Pallet Grapple.

## MAINTENANCE (Model 336)

1. Before each use, look for hydraulic leaks and have them repaired by a qualified repairman if they exist.
2. Remove any items that may have become lodged in the frame, grapple, or under the hydraulic cylinder.